

High-pressure pumps

Series HP43



General

Description / Application

Multi-stage high pressure pumps for water supply, irrigation and industrial applications, for hot and cold water circulation, fire fighting, boiler feed and pressure boosting installations. Suitable for all clean or slightly dirty non-corrosive liquids up to a viscosity of 150 mm²/s (cSt).

Operating range

Nominal branch diameter DN	40-200
Capacity Q	up to 850 m ³ /h
Head H	up to 630 m
Operating pressure p	up to 63 bar
Liquid temperature t	-20°C up to +140°C
Speed n	up to 3600 rpm

Product advantages

- Numerous horizontal and vertical models for an efficient building design.
- Flexible arrangement of suction- and delivery branch.
- Numerous hydraulic units per model size guarantee a design at the optimal operating point.
- High efficiencies owing to optimized hydraulics.
- Optimal adaptability to the medium to be pumped owing to a variety of material and sealing versions.
- Pump shaft protected along its entire length by means of impeller hubs and sleeves.
- Balancing of the axial thrust by means of balancing piston (at high pressure).

Designation

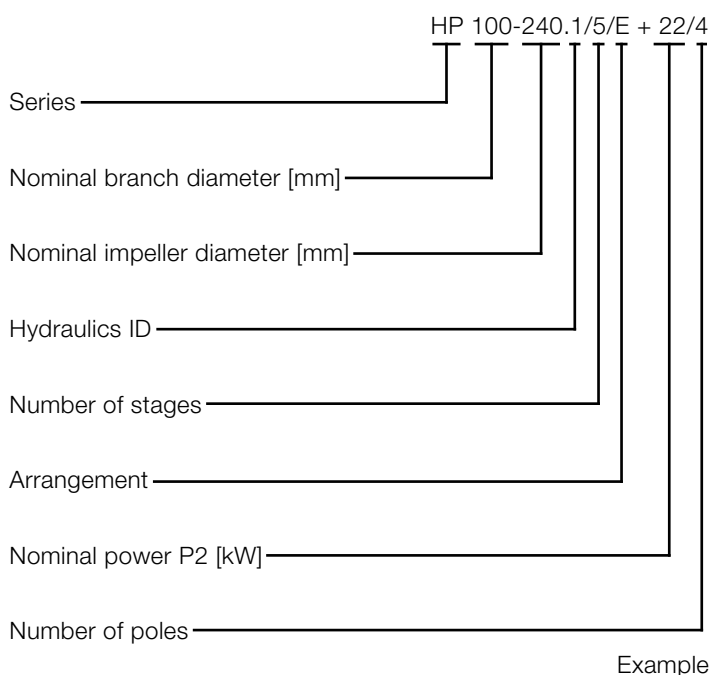

Arrangements



Arrangement A1 and E1

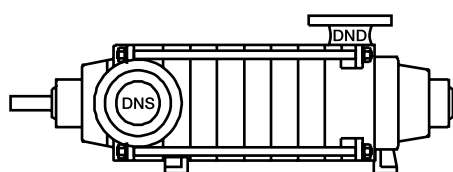

Pump arranged horizontally. Radial suction and delivery connections. On the suction and delivery sides, shaft mounted in grease lubricated ball bearings outside the pump body. Drive on suction side with anti-clockwise rotation, seen from drive end. Pump and motor mounted on a common base plate, connectec by a flexible coupling.

Arrangement A2 and E2

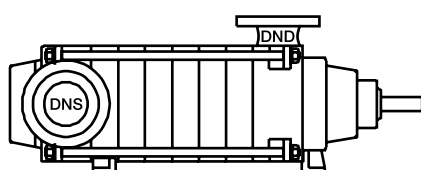

Pump arranged horizontally. Radial suction and delivery connections. On delivery side, shaft mounted outside the pump body in grease lubricated ball bearings, and on suction side rotating in a sleeve bearing lubricated by the pumped medium. Drive on delivery side with clockwise rotation, seen from drive end. Pump and motor mounted on a common base plate, connectec by a flexible coupling.

Arrangement A3 and E3

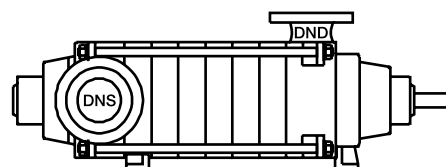

Pump arranged horizontally. Radial suction and delivery connections. On the suction and delivery sides, shaft mounted in grease lubricated ball bearings outside the pump body. Drive on delivery side with clockwise rotation, seen from drive end. Pump and motor mounted on a common base plate, connectec by a flexible coupling.

Arrangement AX

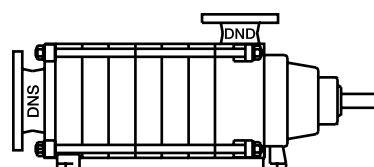

Pump arranged horizontally. Axial suction connection, radial delivery connection. On delivery side, shaft mounted outside the pump body in grease lubricated ball bearings, and on suction side rotating in a sleeve bearing situated within the suction branch lubricated by the pumped medium. Drive on delivery side with clockwise rotation, seen from drive end. Pump and motor mounted on a common base plate, connectec by a flexible coupling. Particularly favourable flow pattern towards the first stage impeller and consequently better suction performance.

Arrangement S

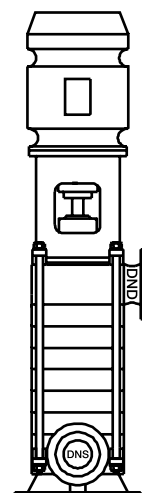

Pump arranged vertically. Radial suction and delivery connections. On the suction side, shaft mounted in a sleeve bearing lubricated by the pumped medium, and on the delivery side mounted in grease lubricated ball bearings. Drive on delivery side with clockwise rotation, seen from drive end. Pump and motor connected via a flexible coupling. Particulary space-saving, easy-to-install design.

Technical details

Constuction

Multi-stage ring section pump of robust construction with extra large shaft section for vibration-free running. For high output pressures additional axial thrust balancing is provided by a balancing piston mounted on pump shaft. All wearing parts are renewable without additional work on the casing parts. Shaft sealing either with mechanical seal or gland packing. Bearing housings are protected against the ingress of spray water by means of lip seals. Under difficult suction conditions (low NPSH-available), the pump can be provided with an axial inlet for cavitation-reducing flow entry pattern into the first stage impeller.

Impellers

At least two types of impellers with matching diffuser are available for each pump frame. Therefore operation within the range of optimum efficiency is possible for the required output conditions. If an abrasive medium is being pumped, the slip face and hub section of the impeller can be protected by renewable rings / bushes in wear resistant materials.

Shaft and bearings

In all the pumps the shaft is protected against wear and corrosion over its entire length by shaft wear sleeves, especially in the area of the shaft seal (mechanical seal or gland packing) and the sleeve bearings in arrangement AX and S. In case of pumps in arrangement A1 and A3, the shaft is mounted outside the pump body in grease lubricated ball bearings (a radial deep groove ball bearing on the suction side and a fixed bearing with paired angular contact ball bearings on the delivery side).

On arrangement A2, AX and S, the shaft is carried in a shielded sleeve bearing lubricated by the pumped medium on the suction side and, on the delivery side, by grease lubricated angular contact ball bearings. All rolling bearings are protected by lip seals.

Shaft sealing

In the standard version the shaft is sealed by mechanical seal acc. to DIN 24960. A shaft sealing by gland packing is available as an option. The packing rings form a seal with a renewable shaft sleeve which protects the shaft against wear.

According to requirements following mechanical seals may be used:

- single acting unbalanced mechanical seal
- single acting balanced mechanical seal
- cartridge seal

Mechanical seals are always mounted on a shaft wear sleeve in stainless steel.

Axial thrust compensation

In pumps with a small number of stages the ball bearings (fixed bearings) absorb the axial thrust. In pumps with a larger number of stages, the axial thrust is equalised by means of a balancing piston mounted on the shaft in the area of the delivery housing.

Slip faces

In order to prevent wear in the slip face and hub area as far as possible interchangeable wear-resisting casing rings and neck bushes are fitted in the housing. The slip faces of the impellers can also be protected by renewable slip rings.

Coupling

Connection between pump and IEC standard motor by flexible coupling N-Eupex, type B.

Drive

- In case of horizontal arrangement by IEC standard motor in form B3 with supporting feet.
- In case of vertical arrangement by IEC standard motor in form V1, with flange connection according to DIN 42948.

Technical details

Branch position

Arrangement A1 and E1, horizontal (standard)

- Drive at suction side.
- Rotation direction of pump shaft is anti-clockwise, seen from drive end.
- Branch position by standard arrangement L3/0.
- Suction and delivery branch to same direction is possible from 3 stages or more.

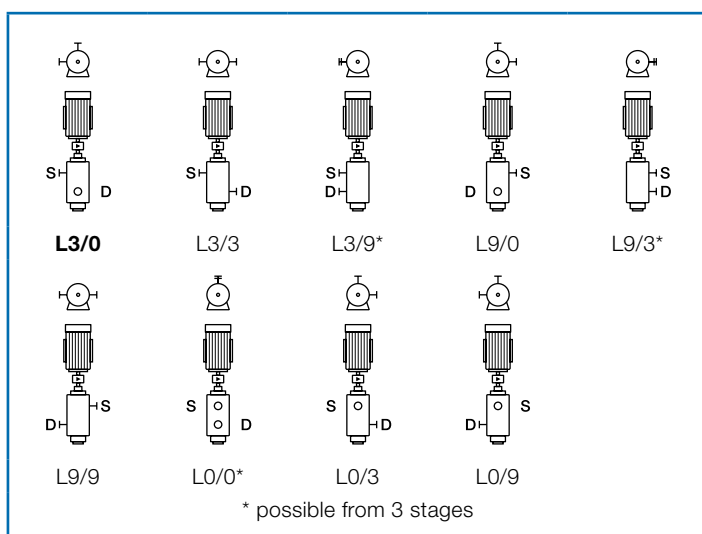

Arrangement A2, E2, A3 and E3, horizontal

- Drive at delivery side.
- Rotation direction of pump shaft is clockwise, seen from drive end.
- Branch position by standard arrangement R3/0.
- Suction and delivery branch to same direction is possible from 3 stages or more.

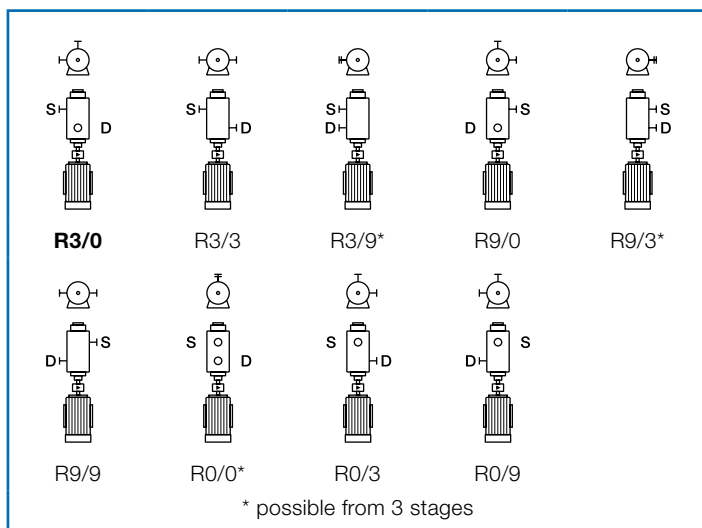

Arrangement AX, horizontal

- Drive at delivery side.
- Rotation direction of pump shaft is clockwise, seen from drive end.
- Branch position by standard arrangement R4/0.

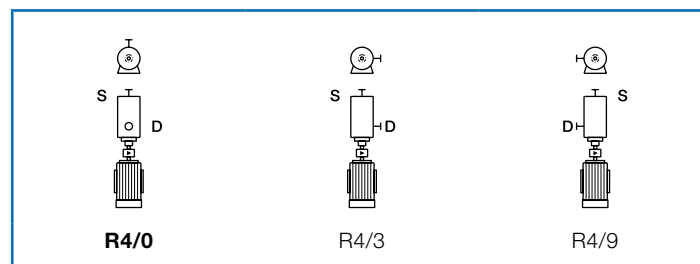

Arrangement S, vertical

- Drive at delivery side.
- Rotation direction of pump shaft is clockwise, seen from drive end.
- Branch position by standard arrangement R9/3.
- Suction and delivery branch to same direction is possible from 3 stages or more.

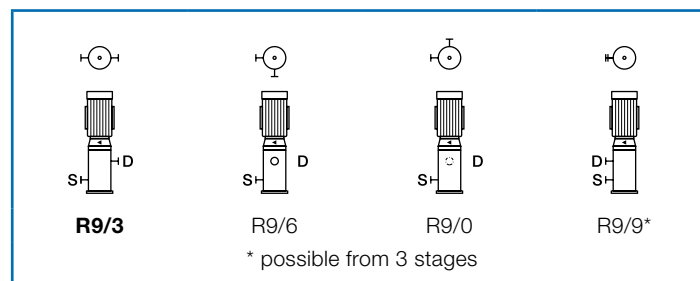

Selection chart

This chart allows a provisional selection of the pump type most suitable for a given set of operating conditions. In certain cases it may be possible to use the next smaller pump type and this possibility should be included in the final selection. For an exact

pump selection our individual characteristic curves as well as our pump selection software WinPump are available.

Speed 980 rpm

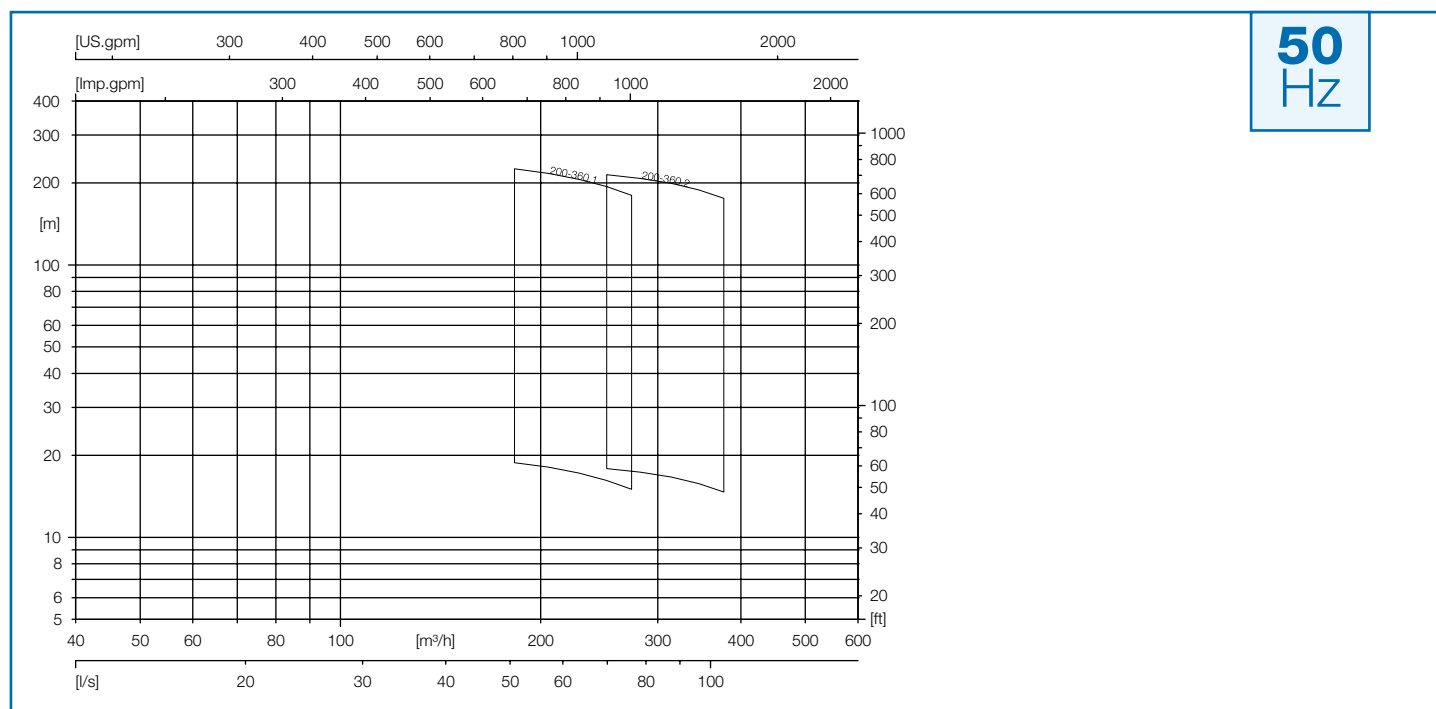

Speed 1150 rpm

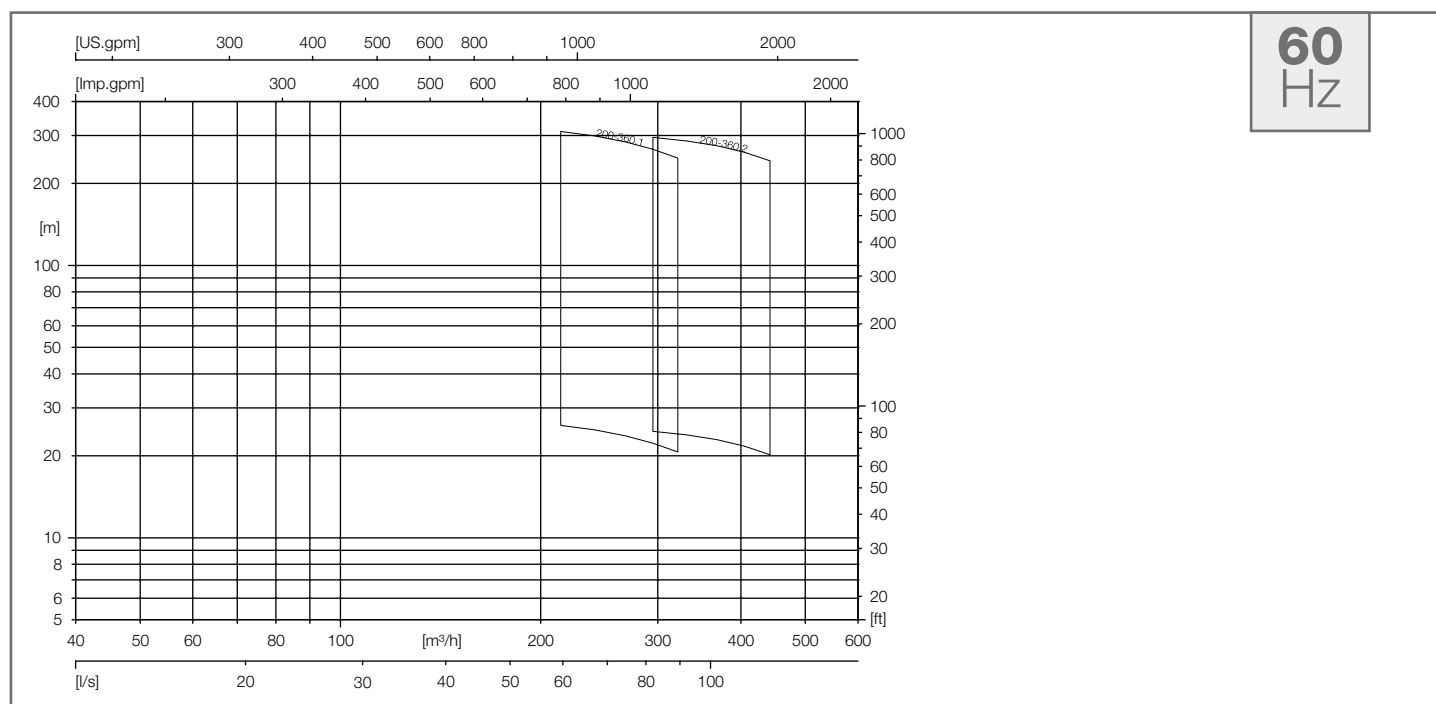

Selection chart

This chart allows a provisional selection of the pump type most suitable for a given set of operating conditions. In certain cases it may be possible to use the next smaller pump type and this possibility should be included in the final selection. For an exact

pump selection our individual characteristic curves as well as our pump selection software WinPump are available.

Speed 1450 rpm

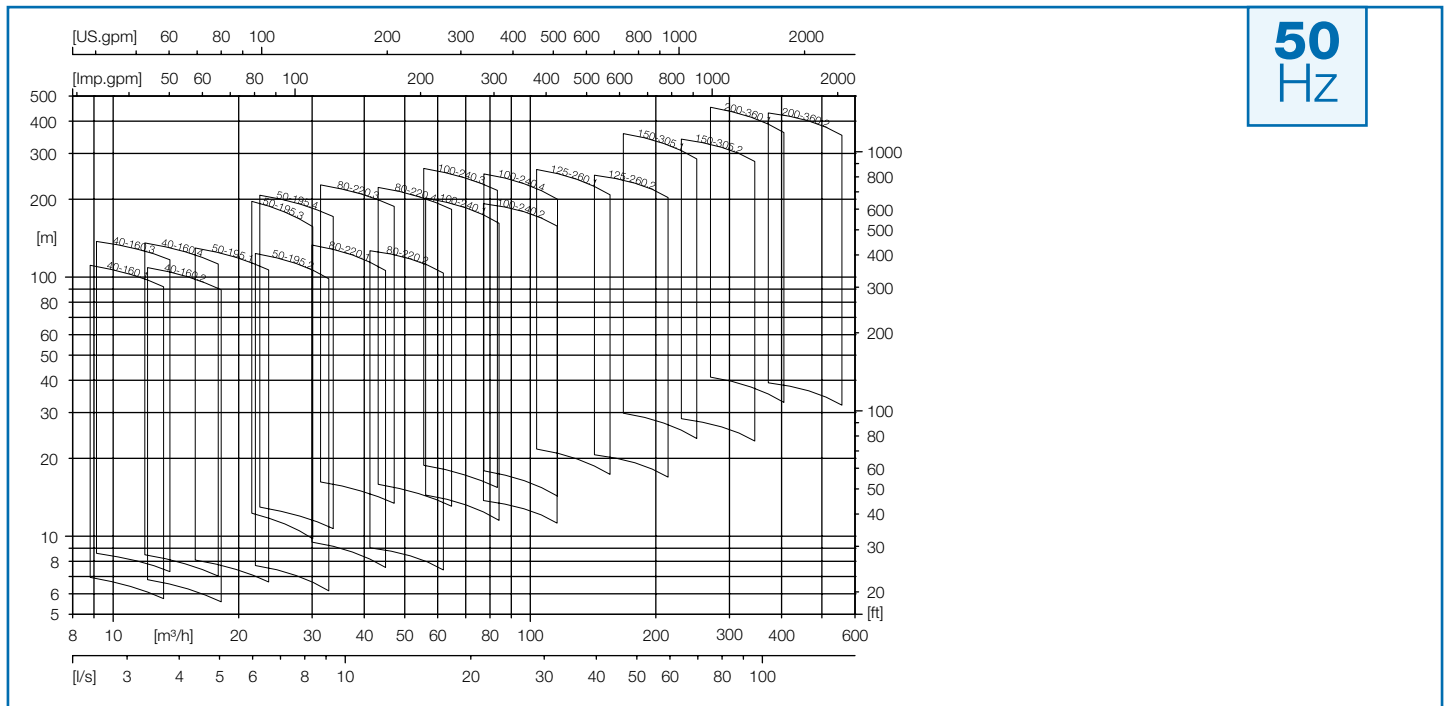

Speed 1760 rpm

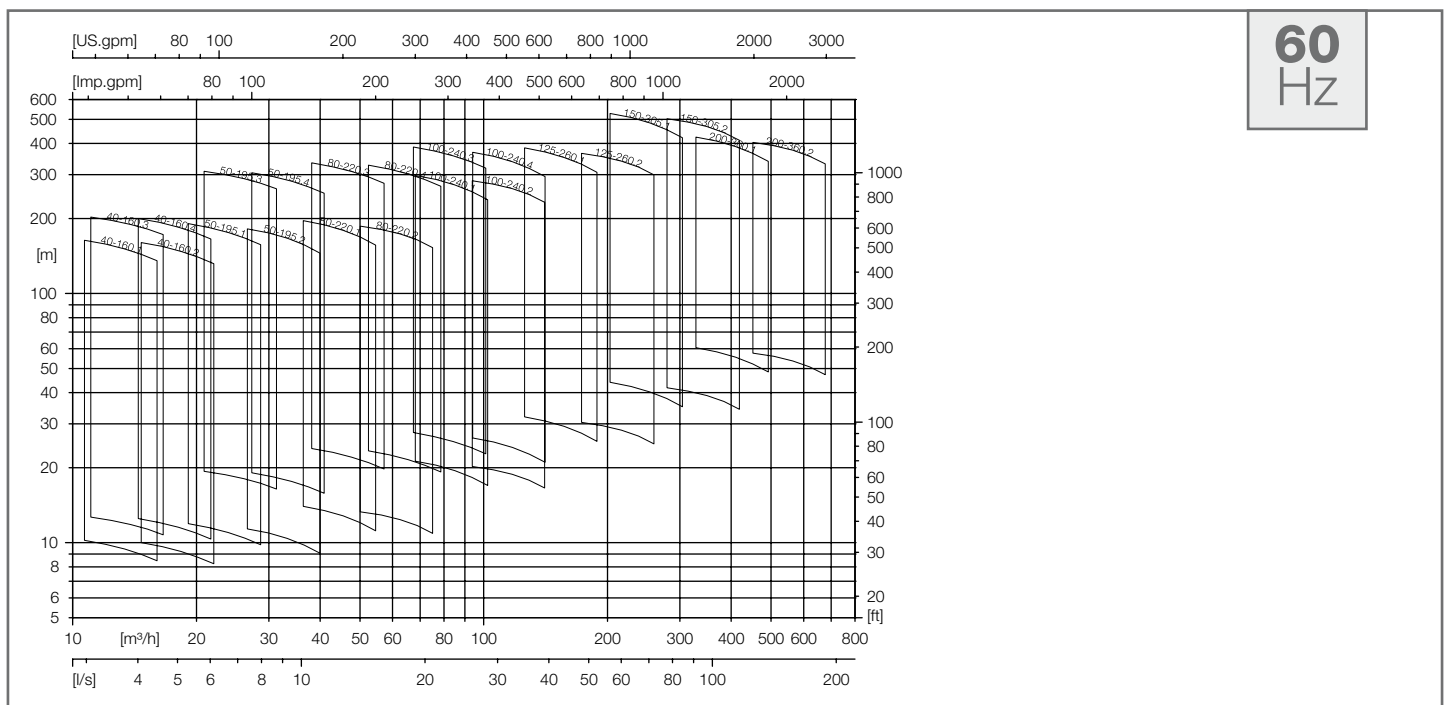

Selection chart

This chart allows a provisional selection of the pump type most suitable for a given set of operating conditions. In certain cases it may be possible to use the next smaller pump type and this possibility should be included in the final selection. For an exact

pump selection our individual characteristic curves as well as our pump selection software WinPump are available.

Speed 2950 rpm

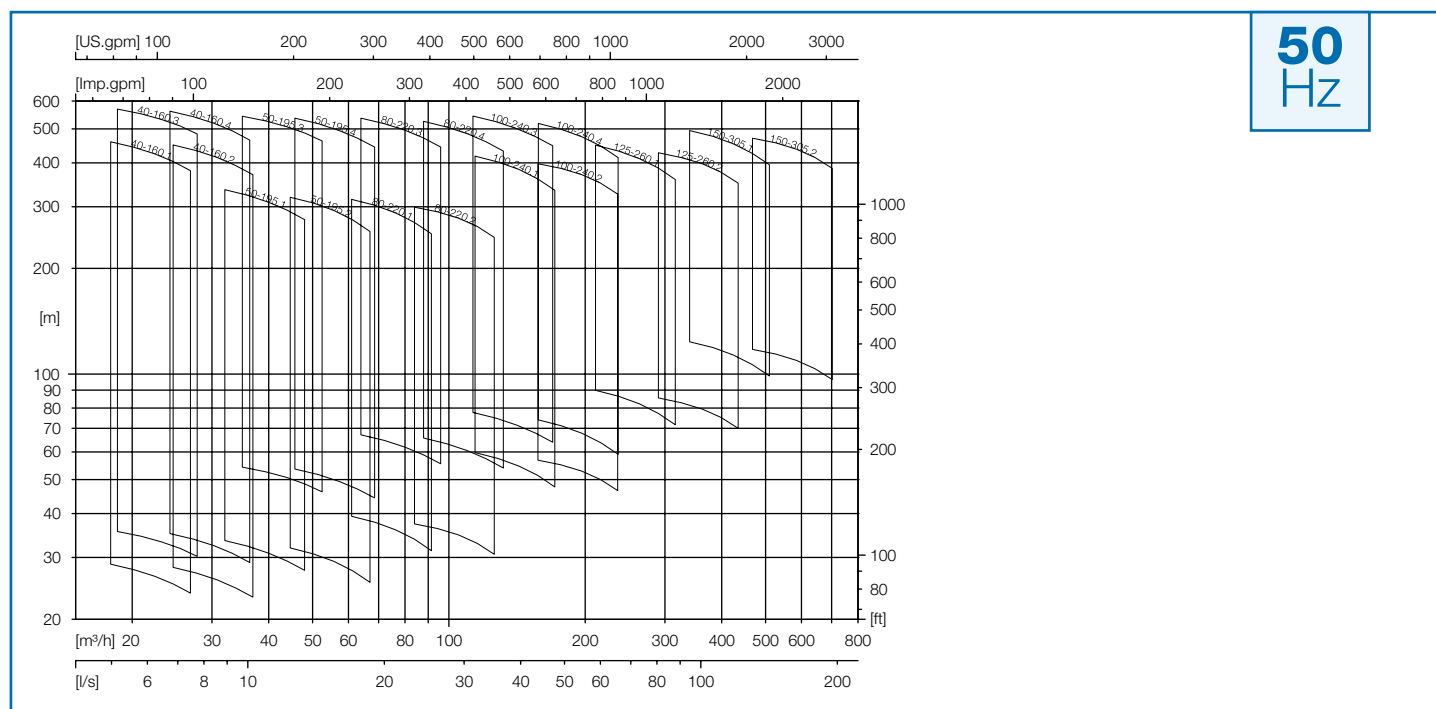

Speed 3600 rpm

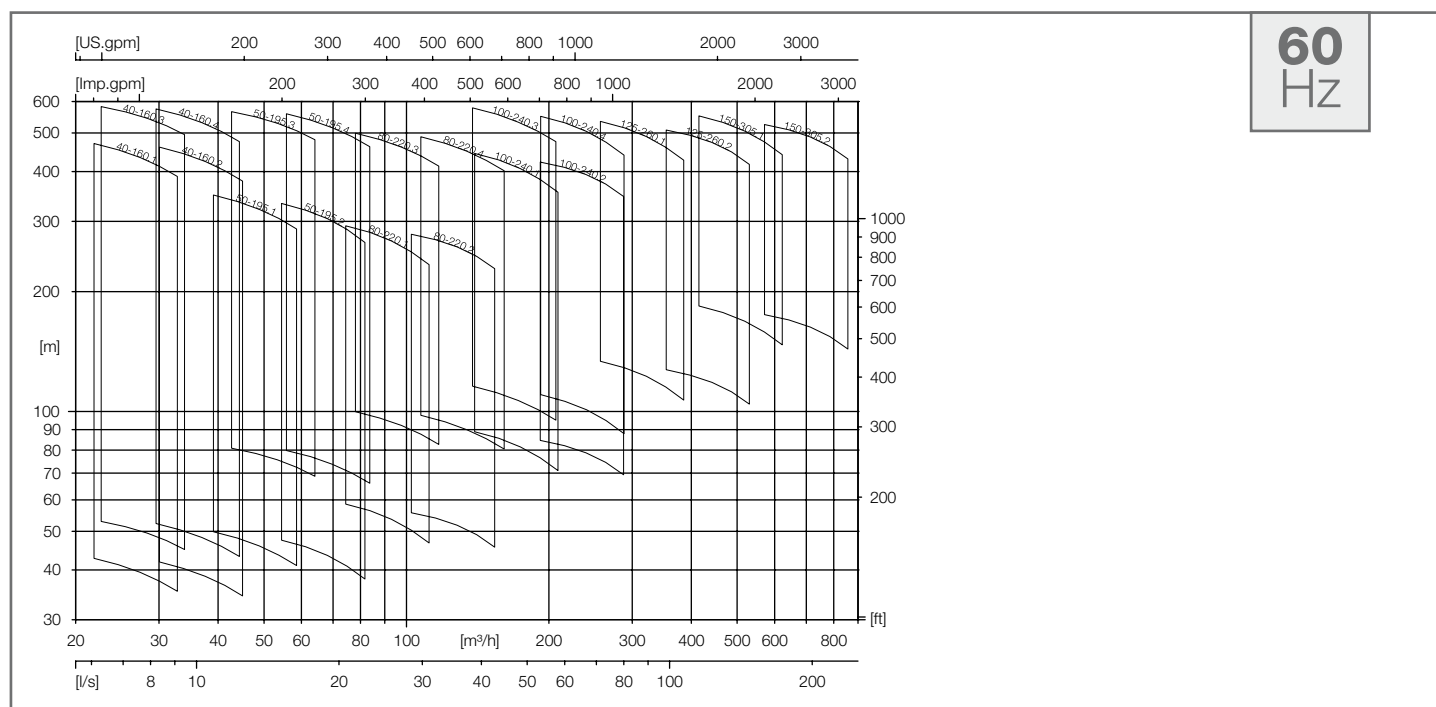

Performance curve

Type 40-160.1

Notes to performance curves

- Curves valid according to DIN EN ISO 9906/2B.
- Power data refers to clean water, density 1 kg/dm³, viscosity 1 mm²/s.
- All duty points between the individual stage characteristics can be achieved by adapting the impeller diameters.

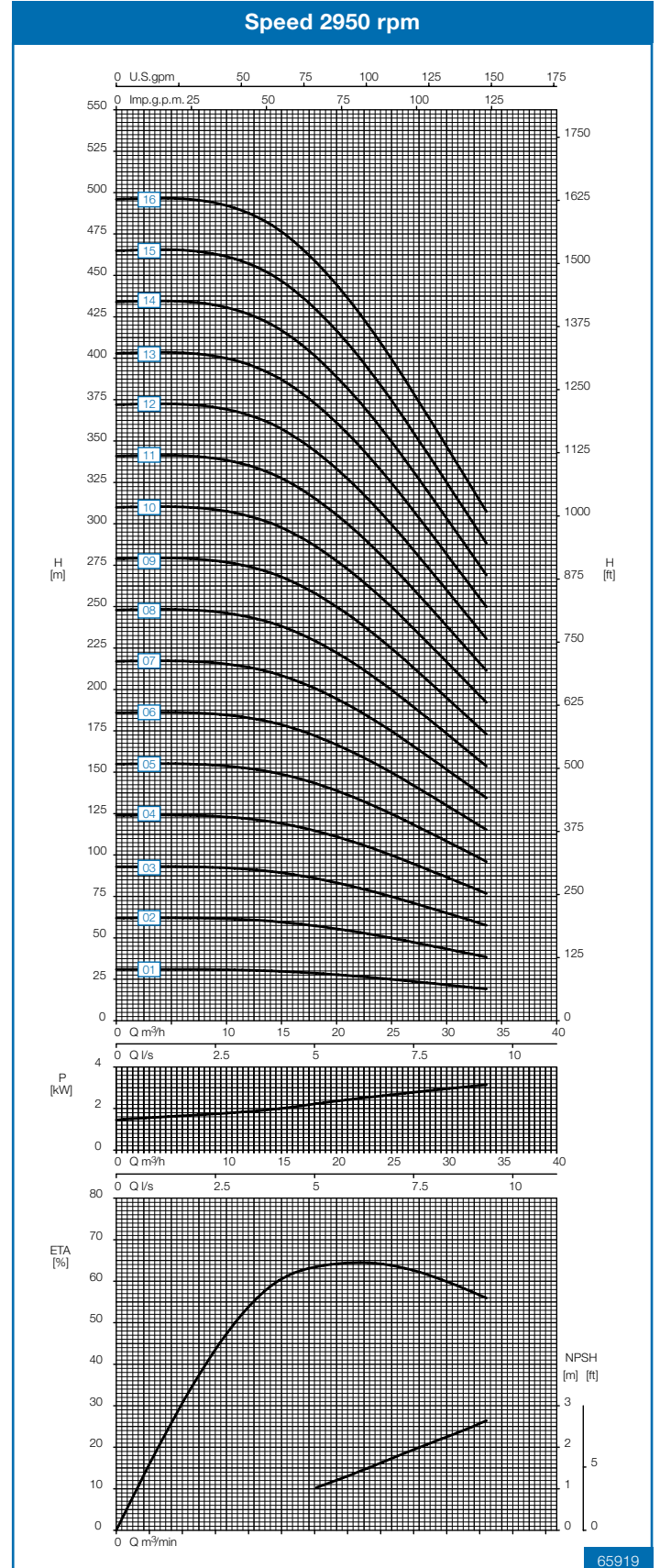
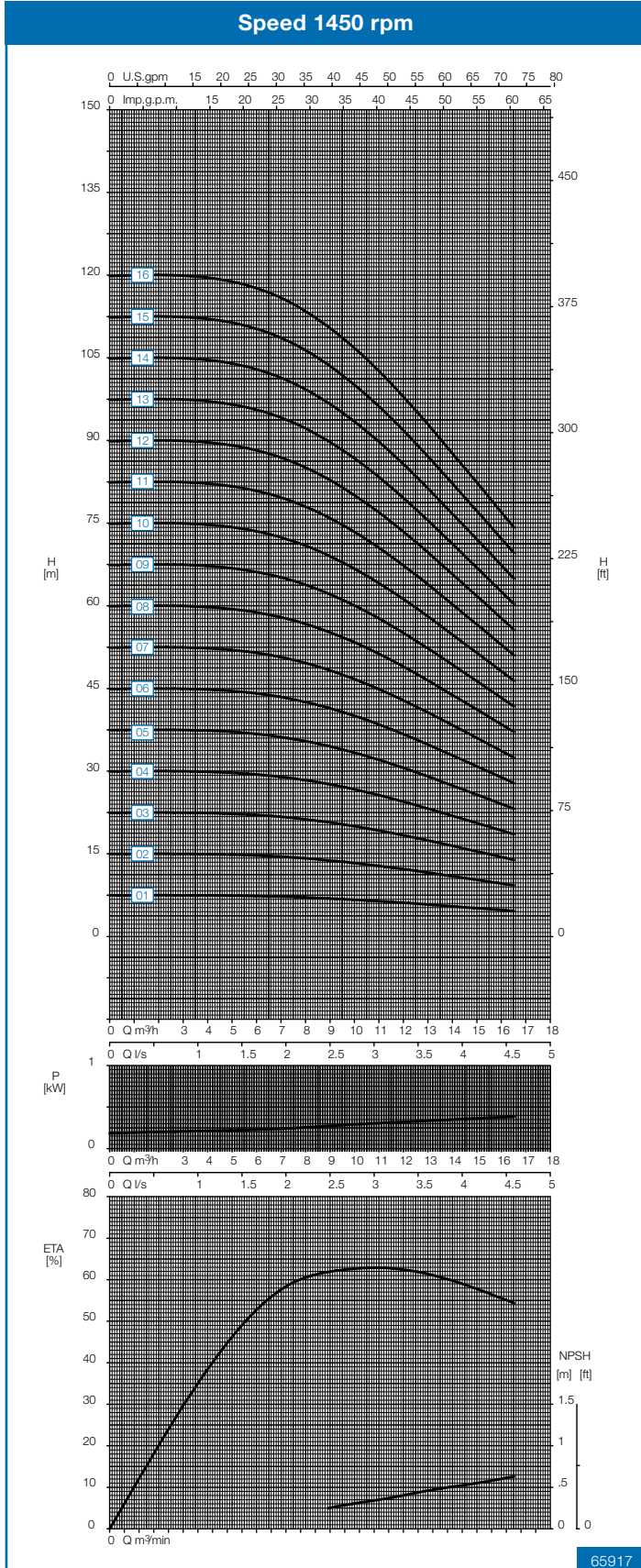

Performance curve

Type 40-160.2

Notes to performance curves

- Curves valid according to DIN EN ISO 9906/2B.
- Power data refers to clean water, density 1 kg/dm³, viscosity 1 mm²/s.
- All duty points between the individual stage characteristics can be achieved by adapting the impeller diameters.

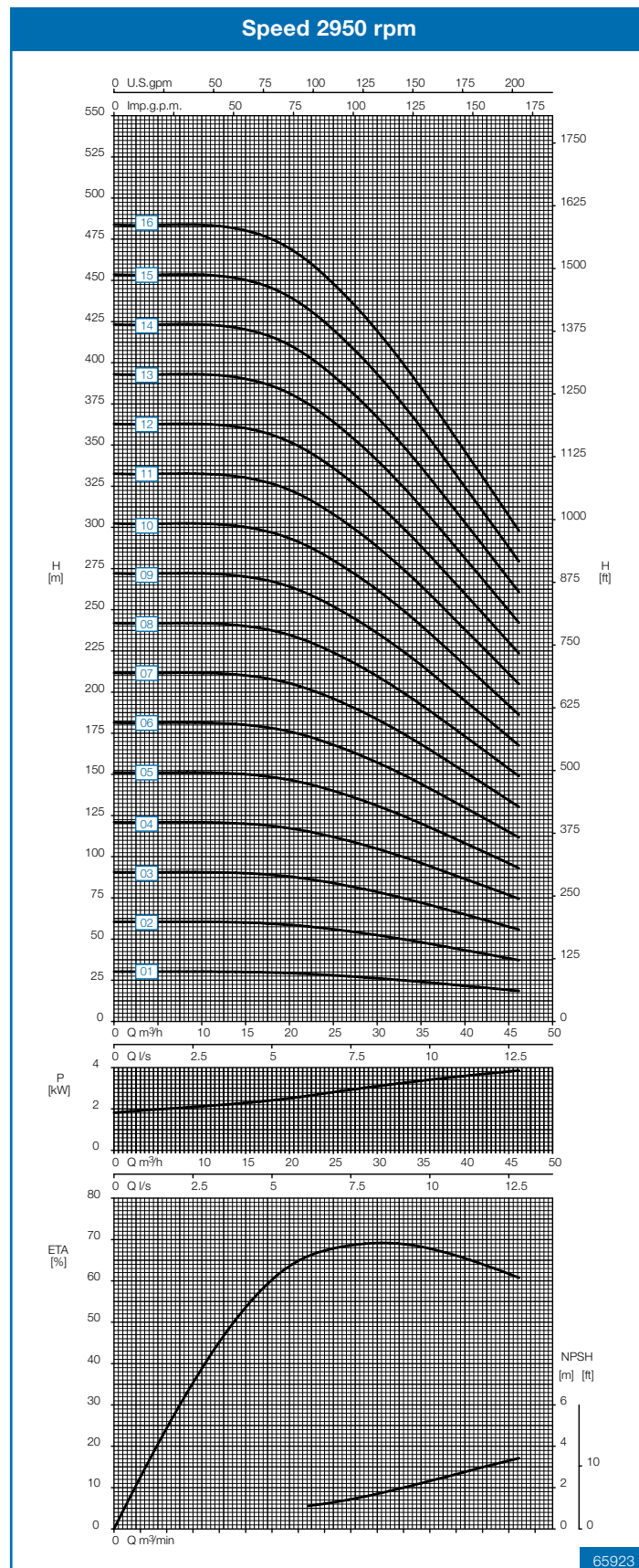
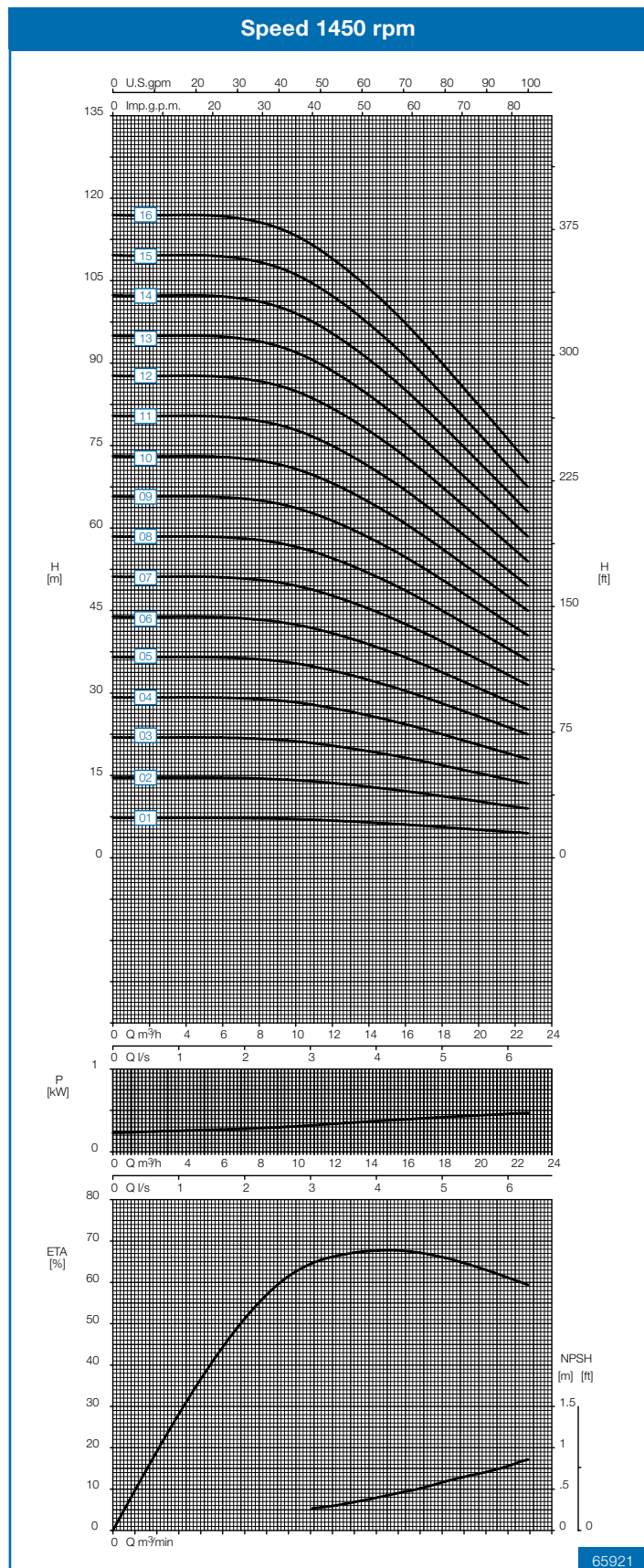

Performance curve

Type 40-160.3

Notes to performance curves

- Curves valid according to DIN EN ISO 9906/2B.
- Power data refers to clean water, density 1 kg/dm³, viscosity 1 mm²/s.
- All duty points between the individual stage characteristics can be achieved by adapting the impeller diameters.

Speed 1450 rpm

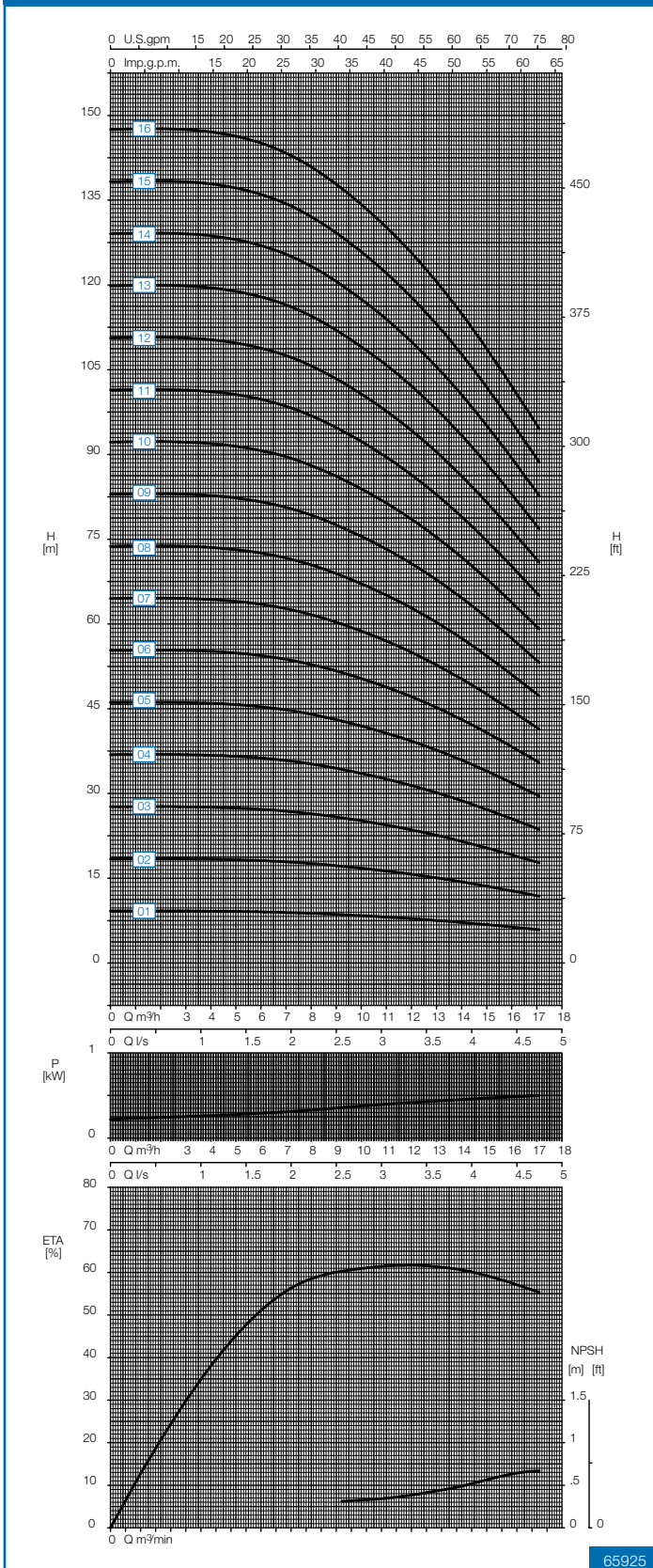

65925

Speed 2950 rpm

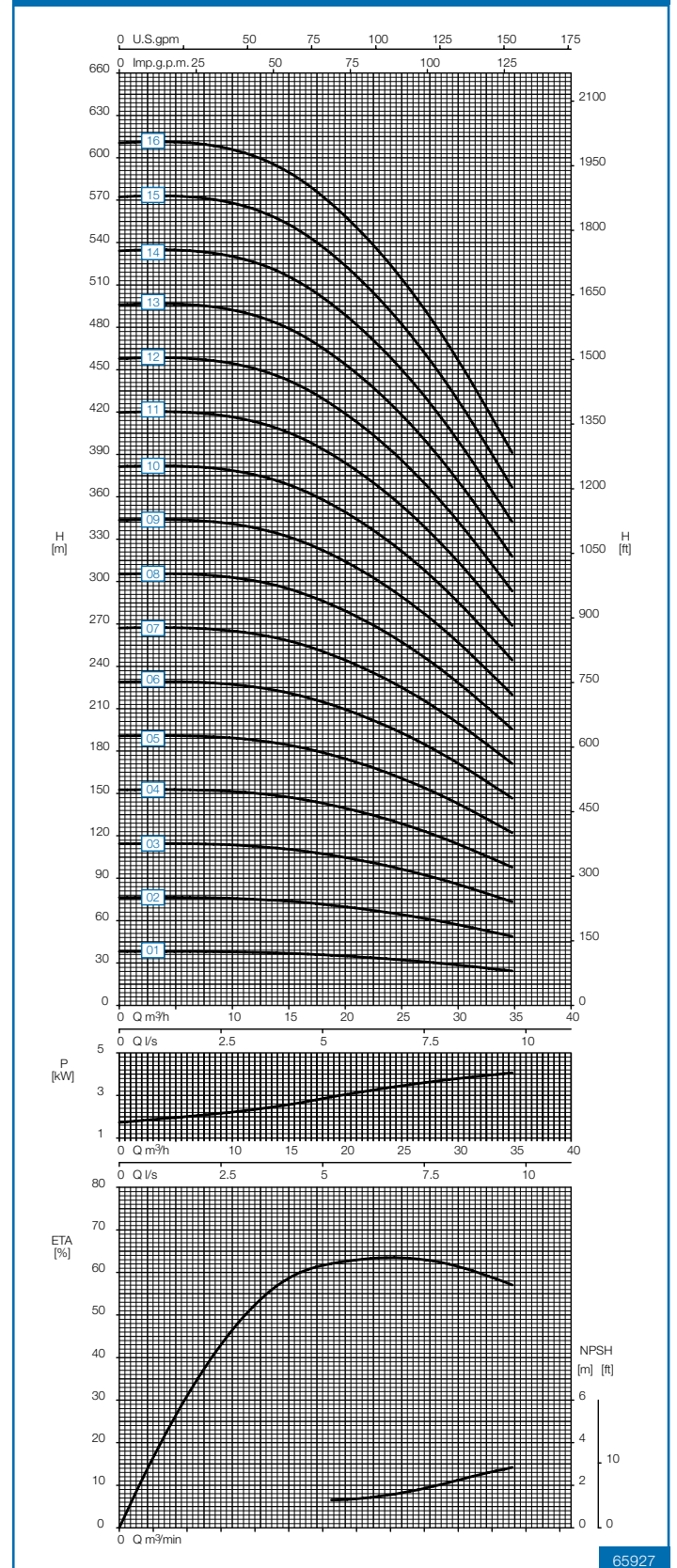

65927

Performance curve

Type 40-160.4

Notes to performance curves

- Curves valid according to DIN EN ISO 9906/2B.
- Power data refers to clean water, density 1 kg/dm³, viscosity 1 mm²/s.
- All duty points between the individual stage characteristics can be achieved by adapting the impeller diameters.

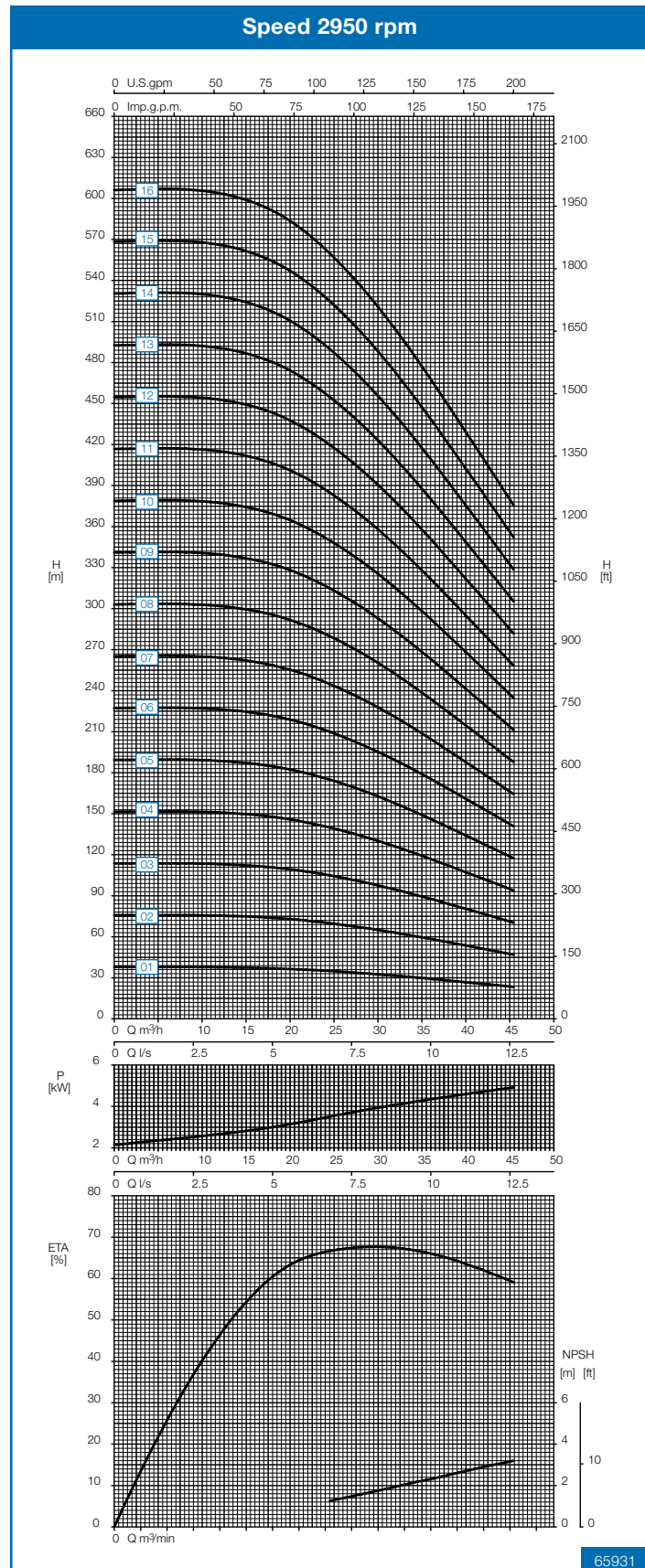
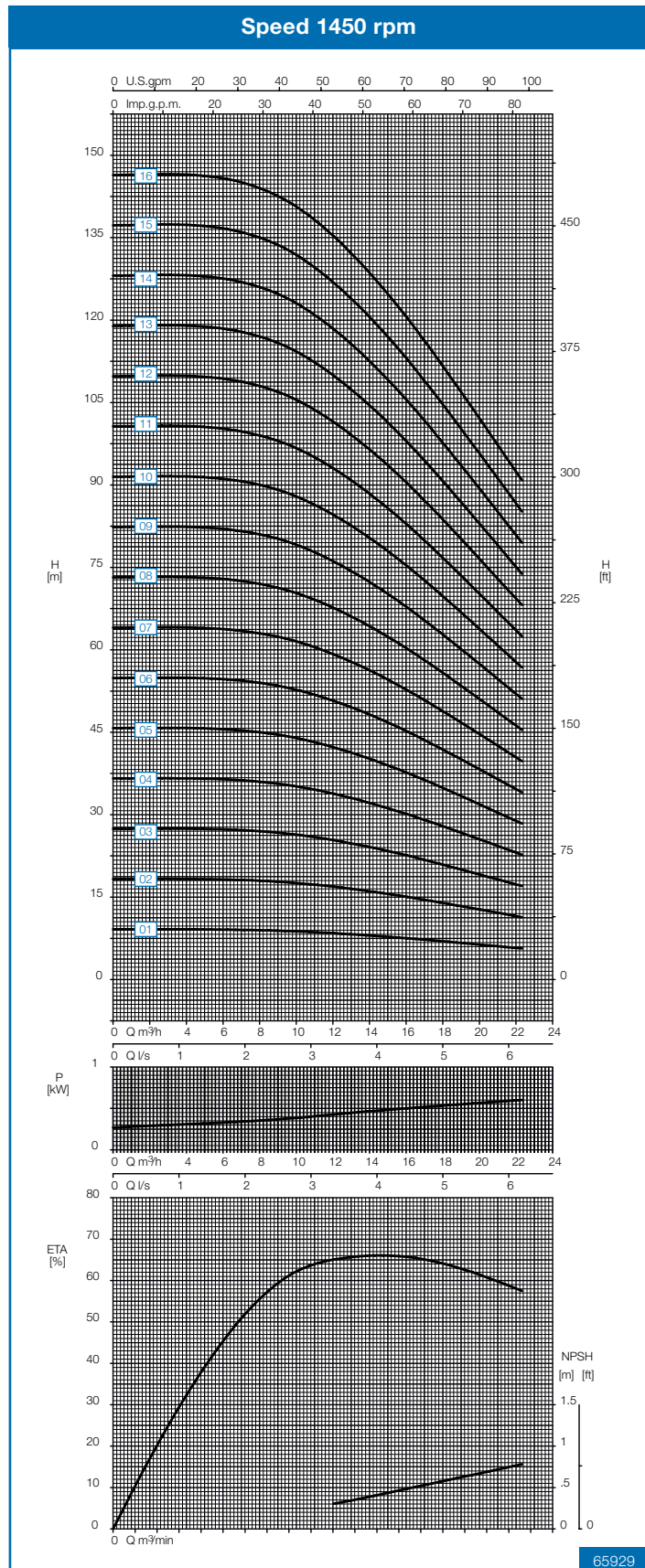

Performance curve

Type 50-195.1

Notes to performance curves

- Curves valid according to DIN EN ISO 9906/2B.
- Power data refers to clean water, density 1 kg/dm³, viscosity 1 mm²/s.
- All duty points between the individual stage characteristics can be achieved by adapting the impeller diameters.

Speed 1450 rpm

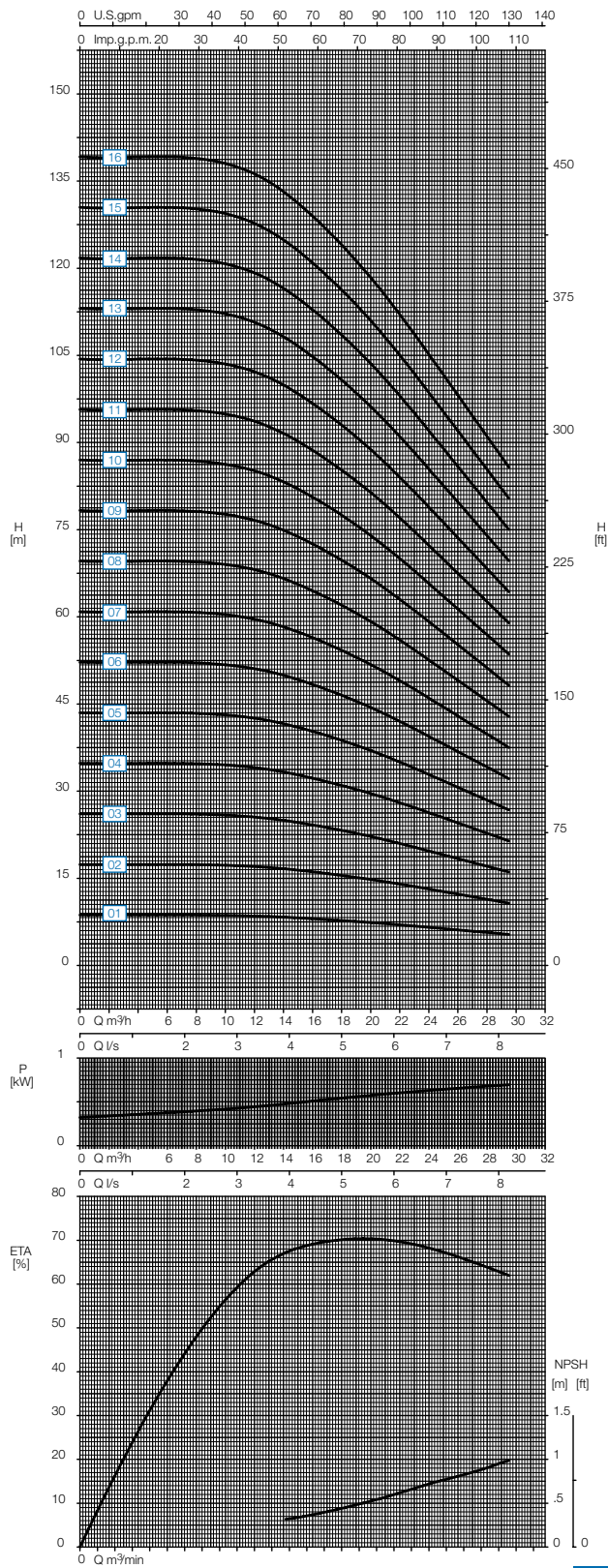

65933

Speed 2950 rpm

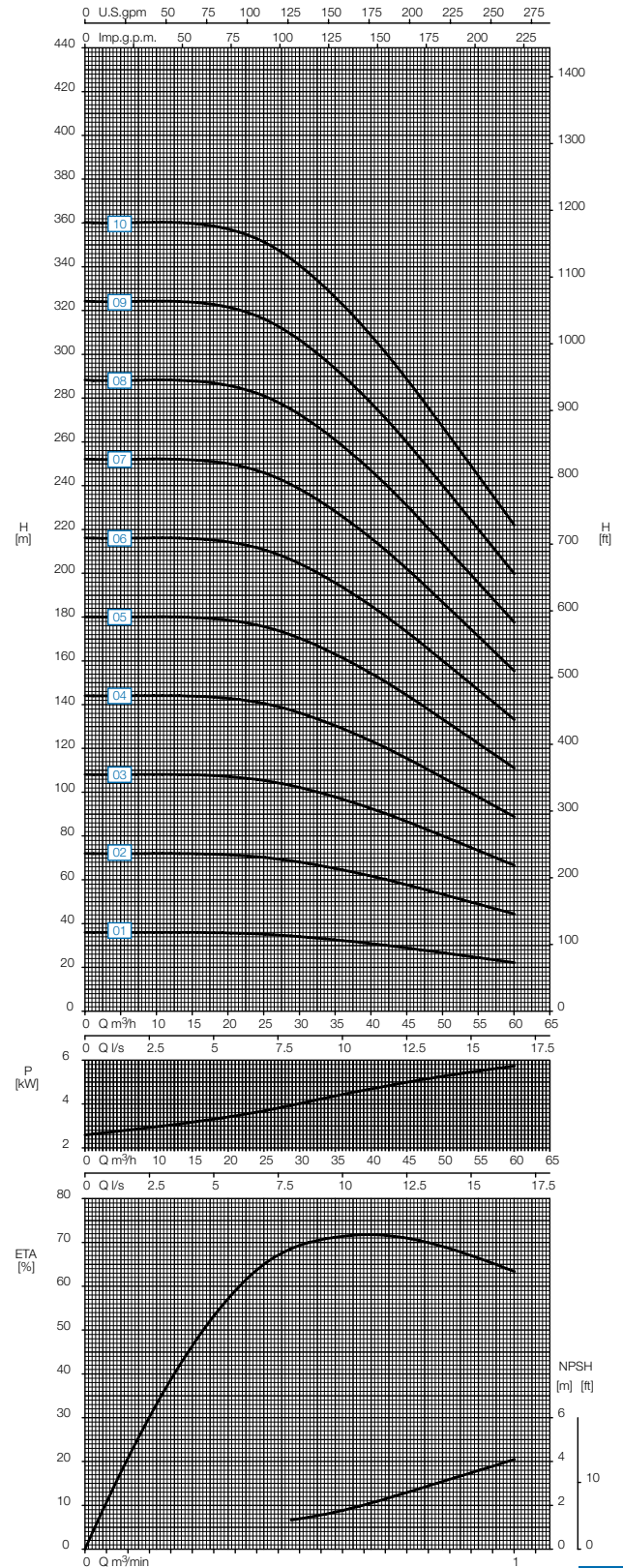

65935

Performance curve

Type 50-195.2

Notes to performance curves

- Curves valid according to DIN EN ISO 9906/2B.
- Power data refers to clean water, density 1 kg/dm³, viscosity 1 mm²/s.
- All duty points between the individual stage characteristics can be achieved by adapting the impeller diameters.

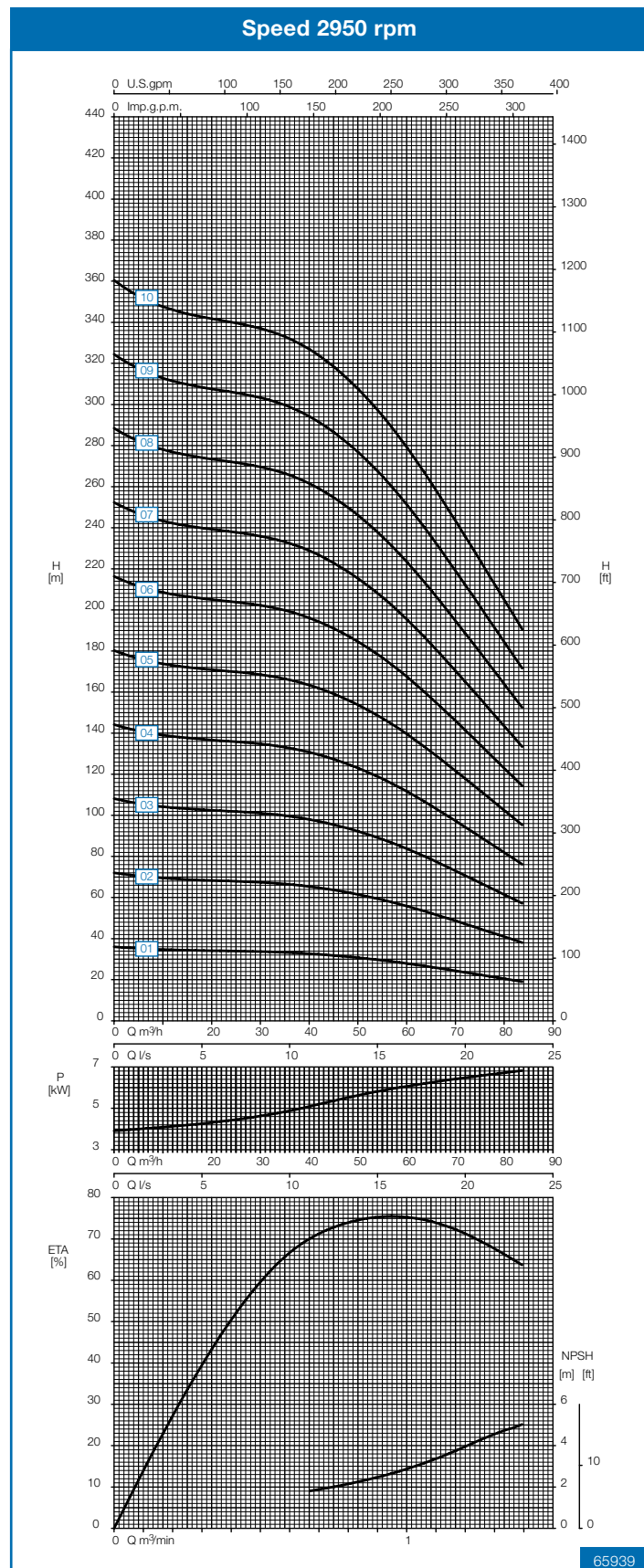
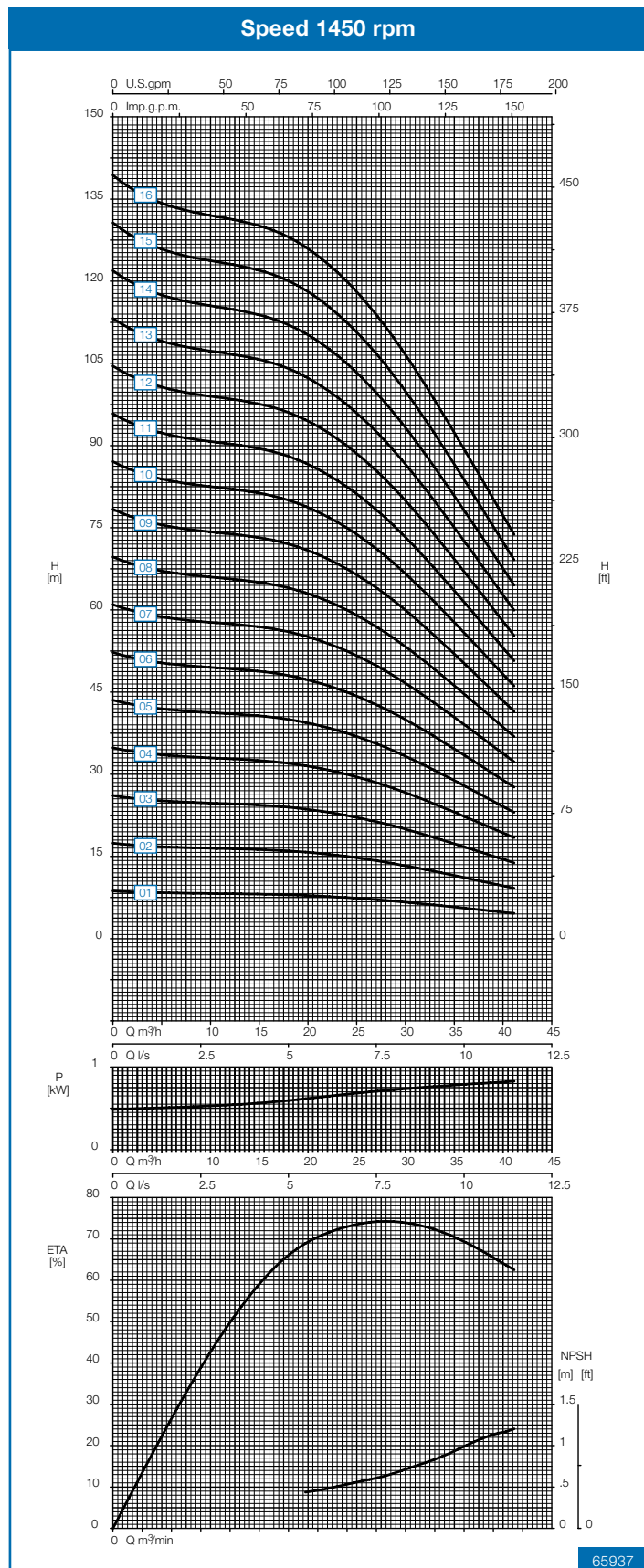

Performance curve

Type 50-195.3

Notes to performance curves

- Curves valid according to DIN EN ISO 9906/2B.
- Power data refers to clean water, density 1 kg/dm³, viscosity 1 mm²/s.
- All duty points between the individual stage characteristics can be achieved by adapting the impeller diameters.

Speed 1450 rpm

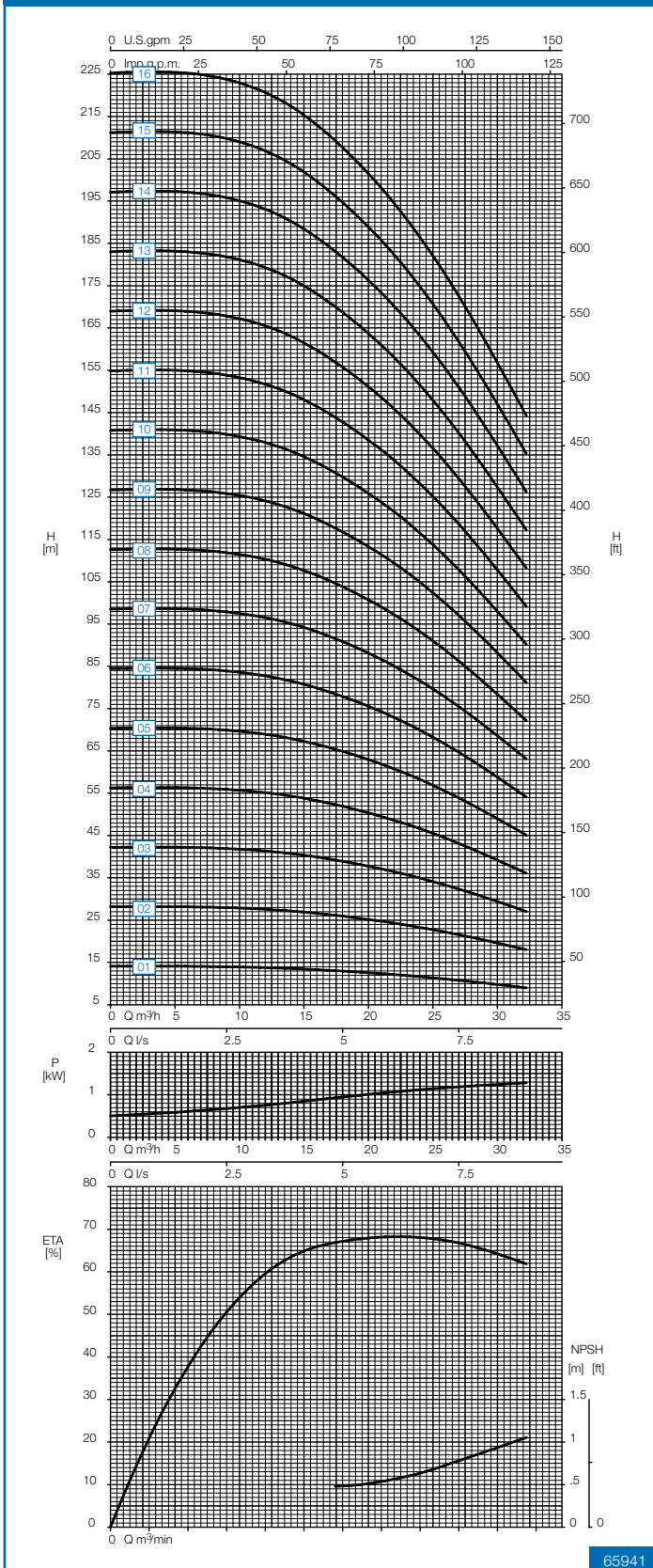

65941

Speed 2950 rpm

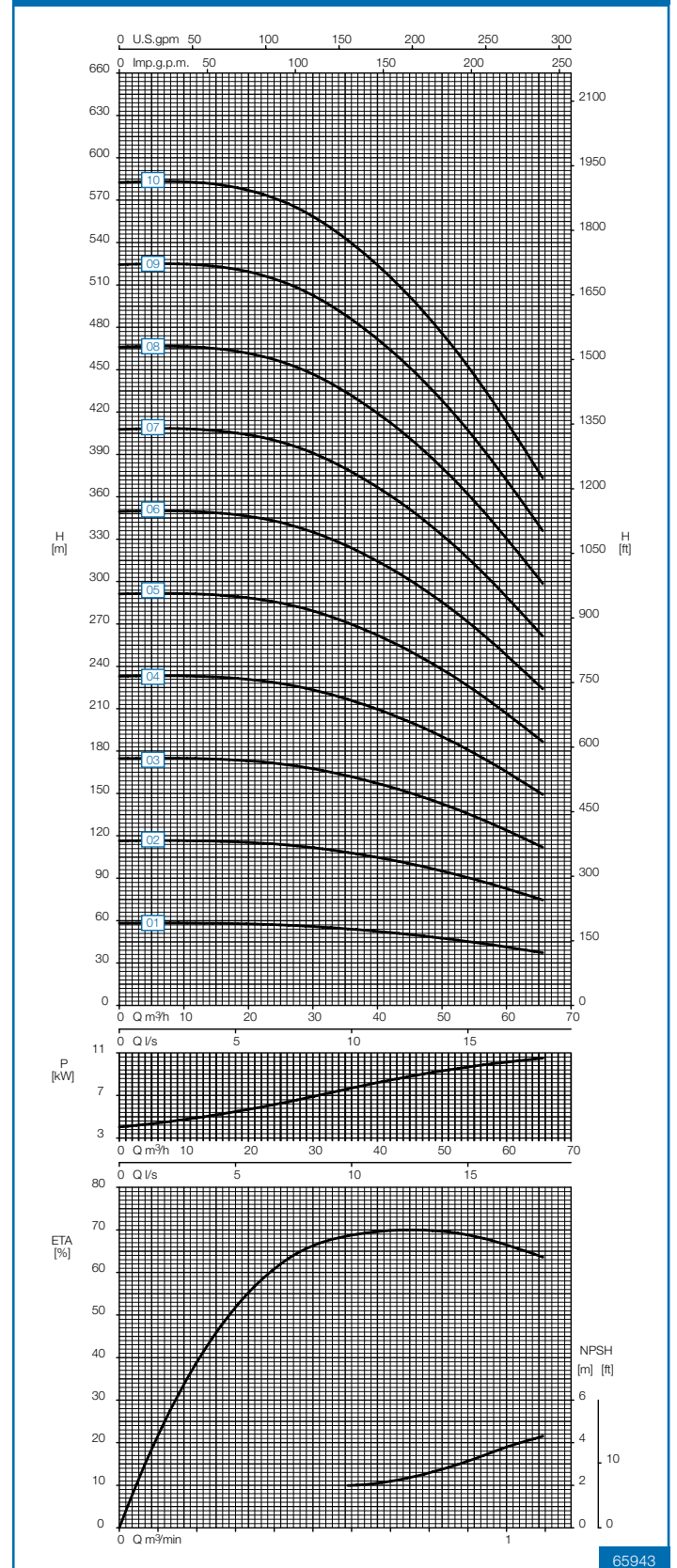

65943

Performance curve

Type 50-195.4

Notes to performance curves

- Curves valid according to DIN EN ISO 9906/2B.
- Power data refers to clean water, density 1 kg/dm³, viscosity 1 mm²/s.
- All duty points between the individual stage characteristics can be achieved by adapting the impeller diameters.

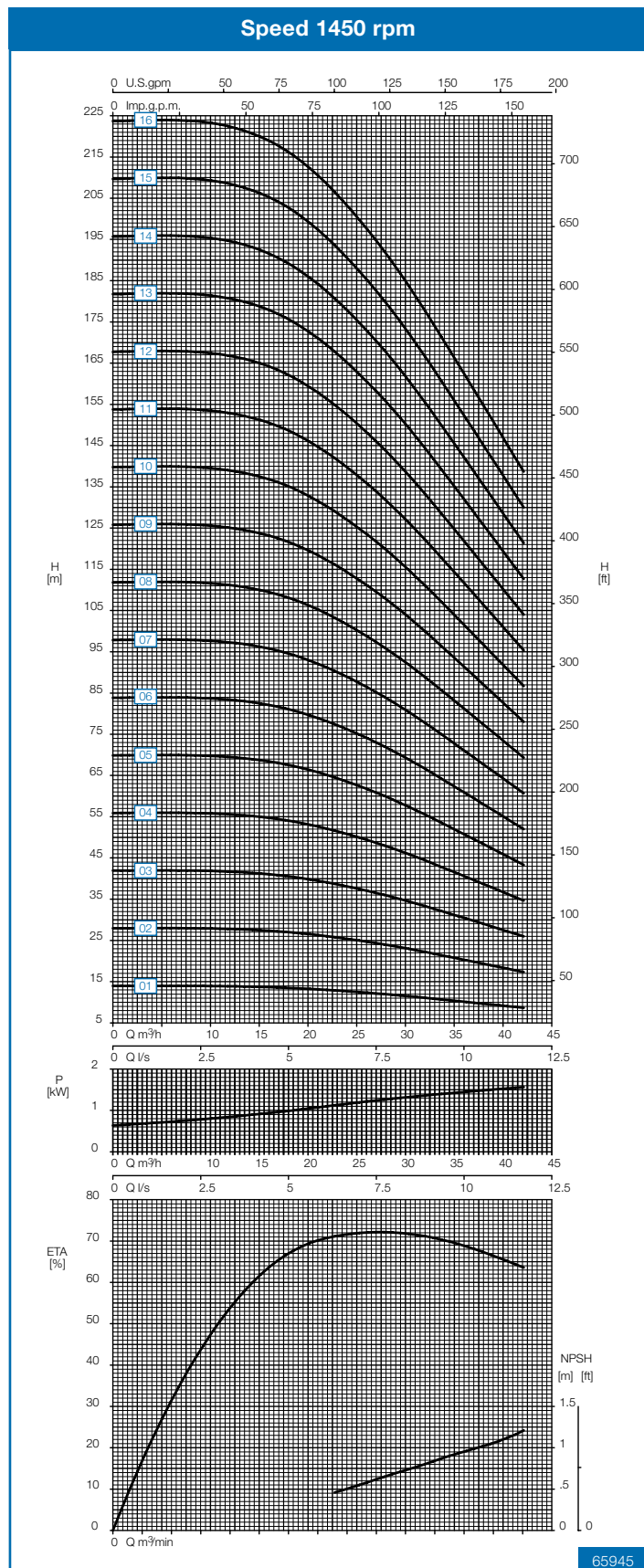

65945

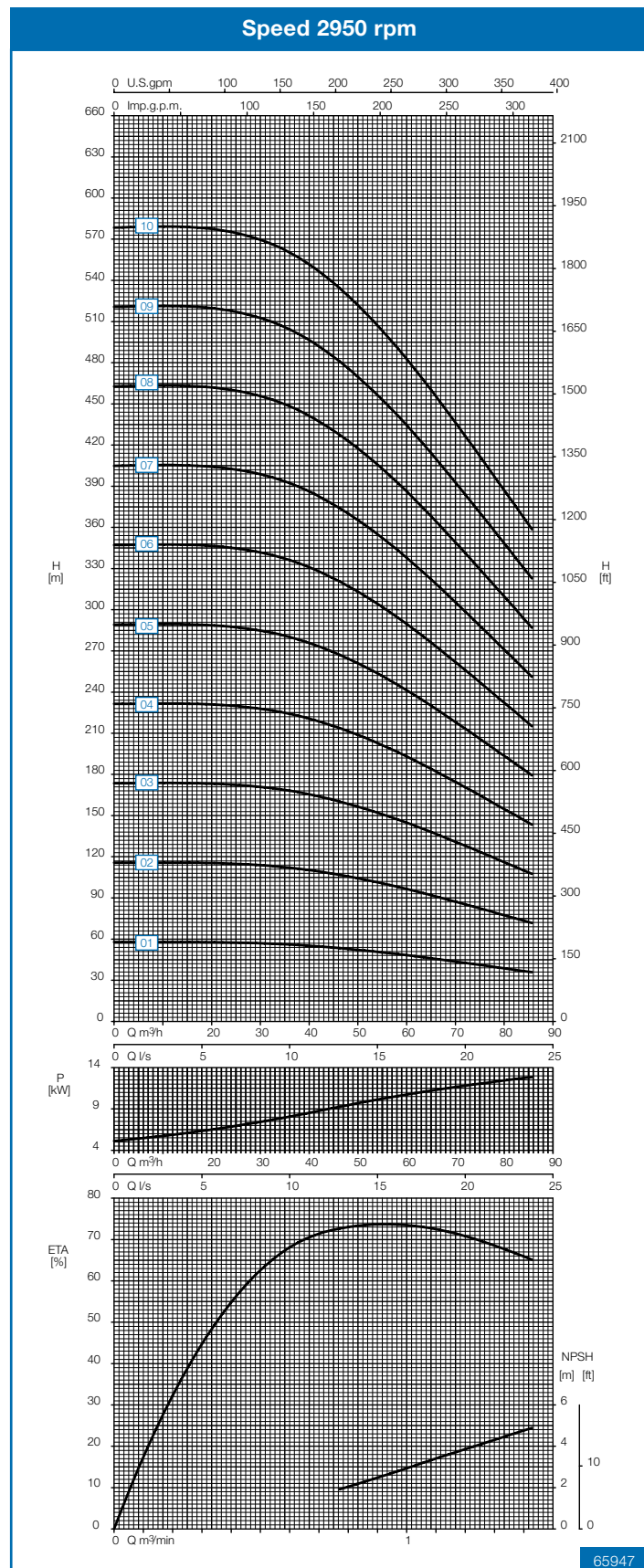

65947

Performance curve

Type 80-220.1

Notes to performance curves

- Curves valid according to DIN EN ISO 9906/2B.
- Power data refers to clean water, density 1 kg/dm³, viscosity 1 mm²/s.
- All duty points between the individual stage characteristics can be achieved by adapting the impeller diameters.

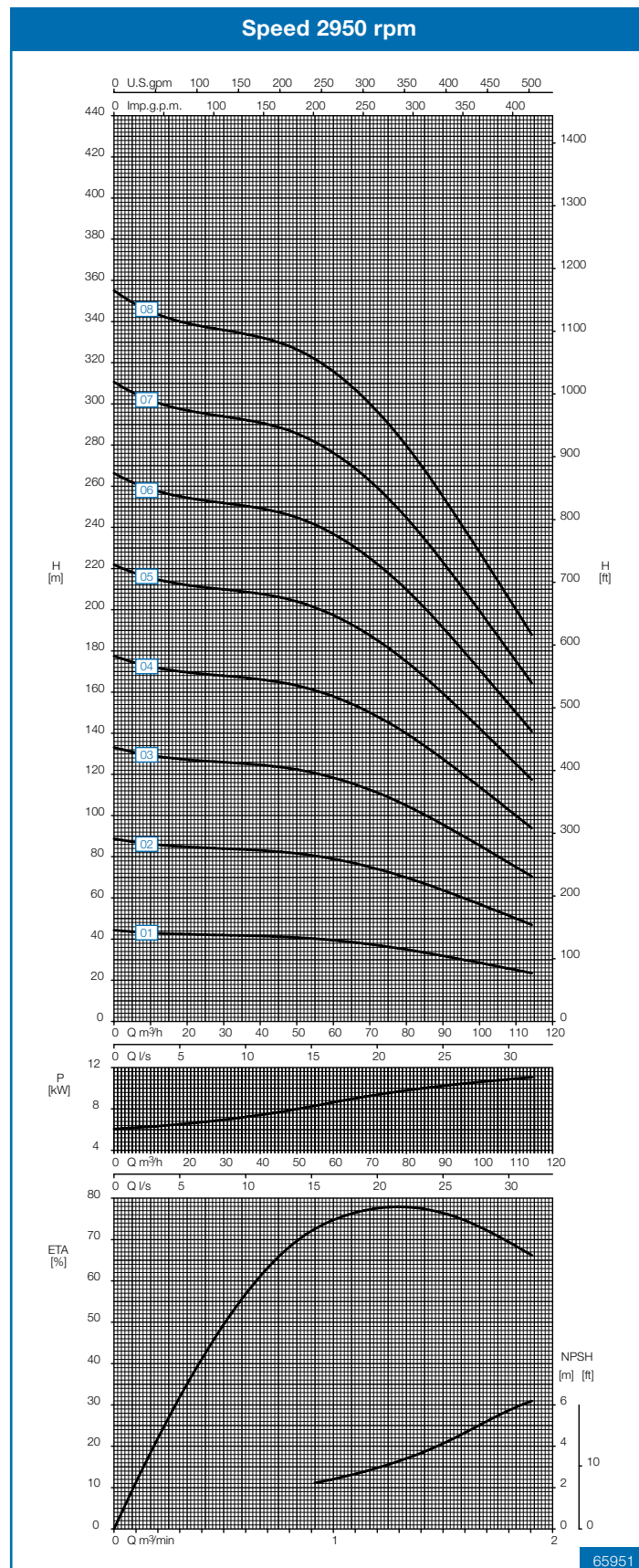
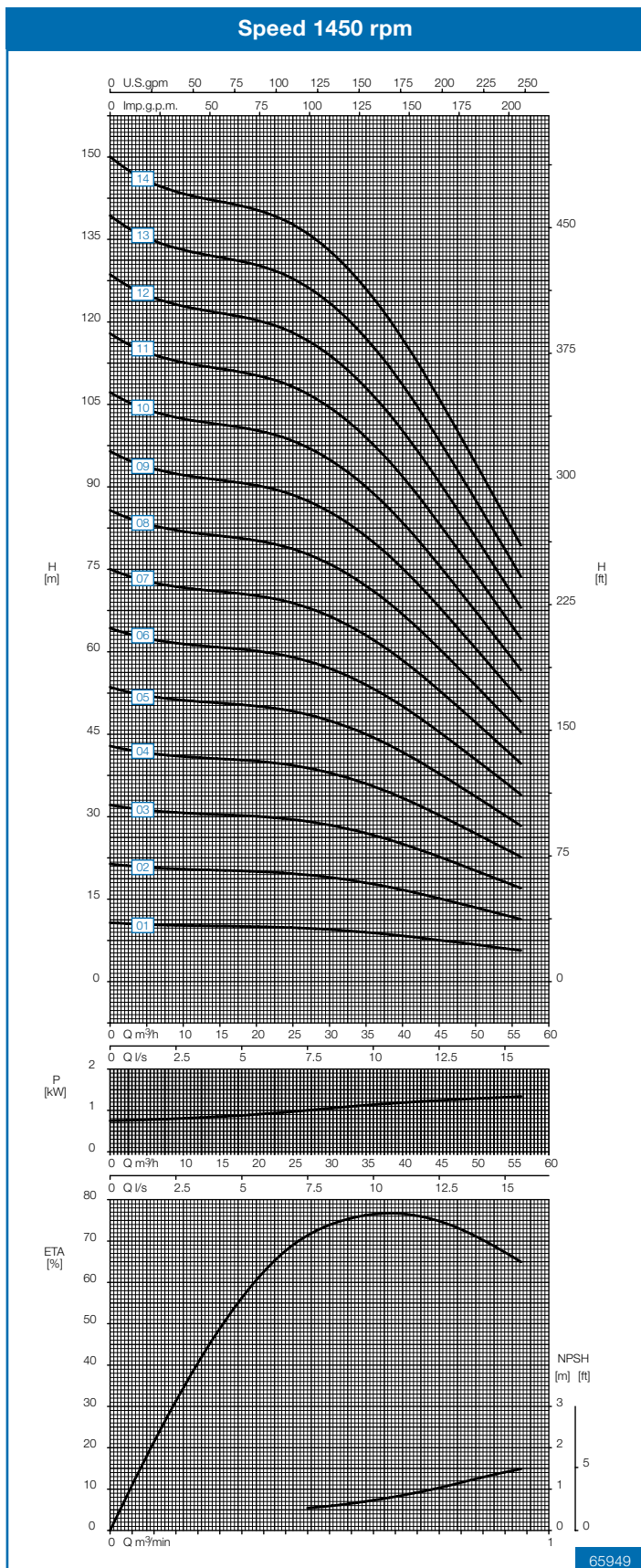

Performance curve

Type 80-220.2

Notes to performance curves

- Curves valid according to DIN EN ISO 9906/2B.
- Power data refers to clean water, density 1 kg/dm³, viscosity 1 mm²/s.
- All duty points between the individual stage characteristics can be achieved by adapting the impeller diameters.

Speed 1450 rpm

Speed 2950 rpm

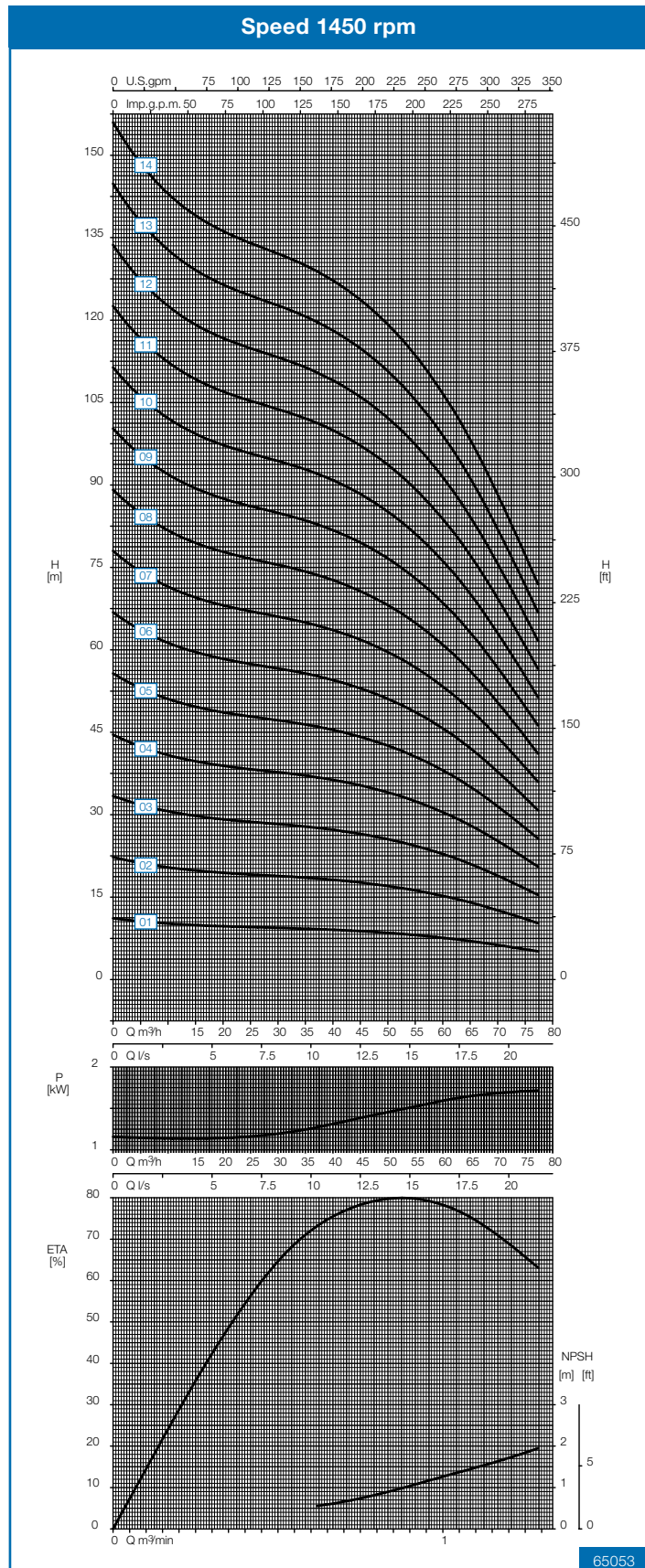

65053

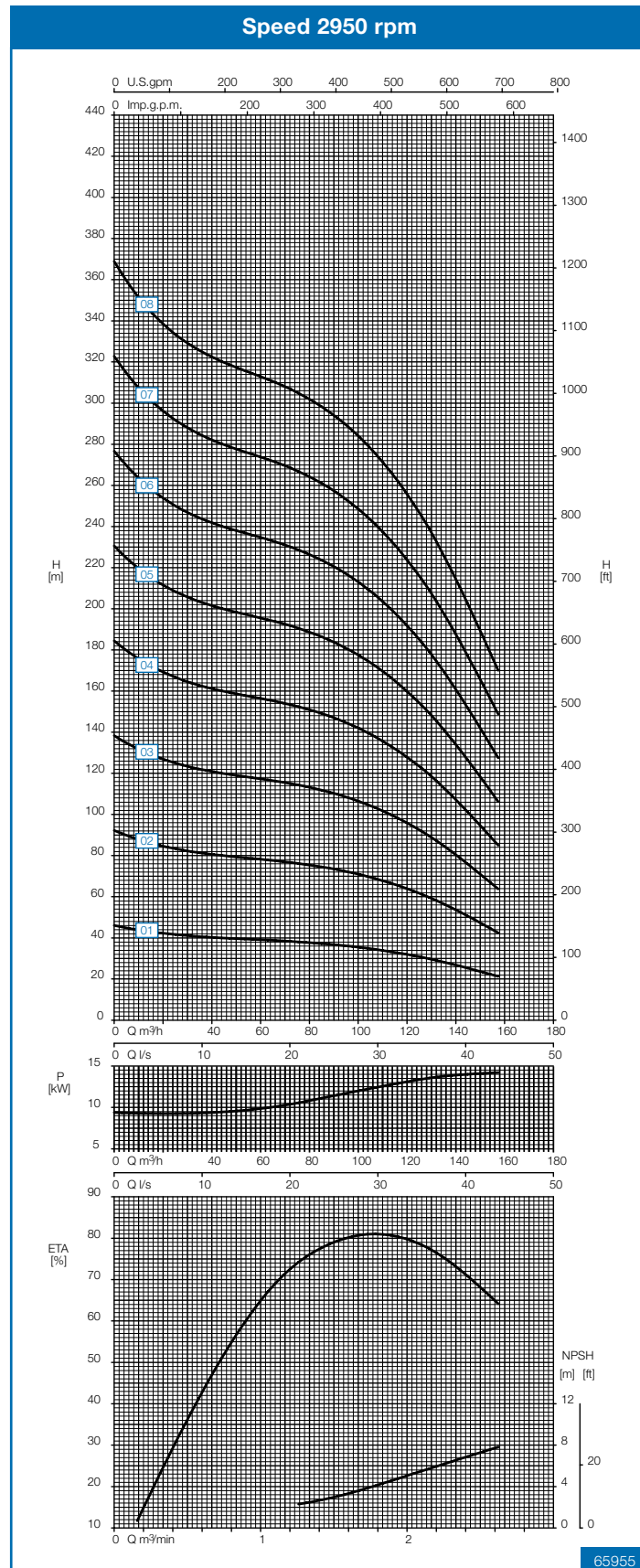

65955

Performance curve

Type 80-220.3

Notes to performance curves

- Curves valid according to DIN EN ISO 9906/2B.
- Power data refers to clean water, density 1 kg/dm³, viscosity 1 mm²/s.
- All duty points between the individual stage characteristics can be achieved by adapting the impeller diameters.

Speed 1450 rpm

Speed 2950 rpm

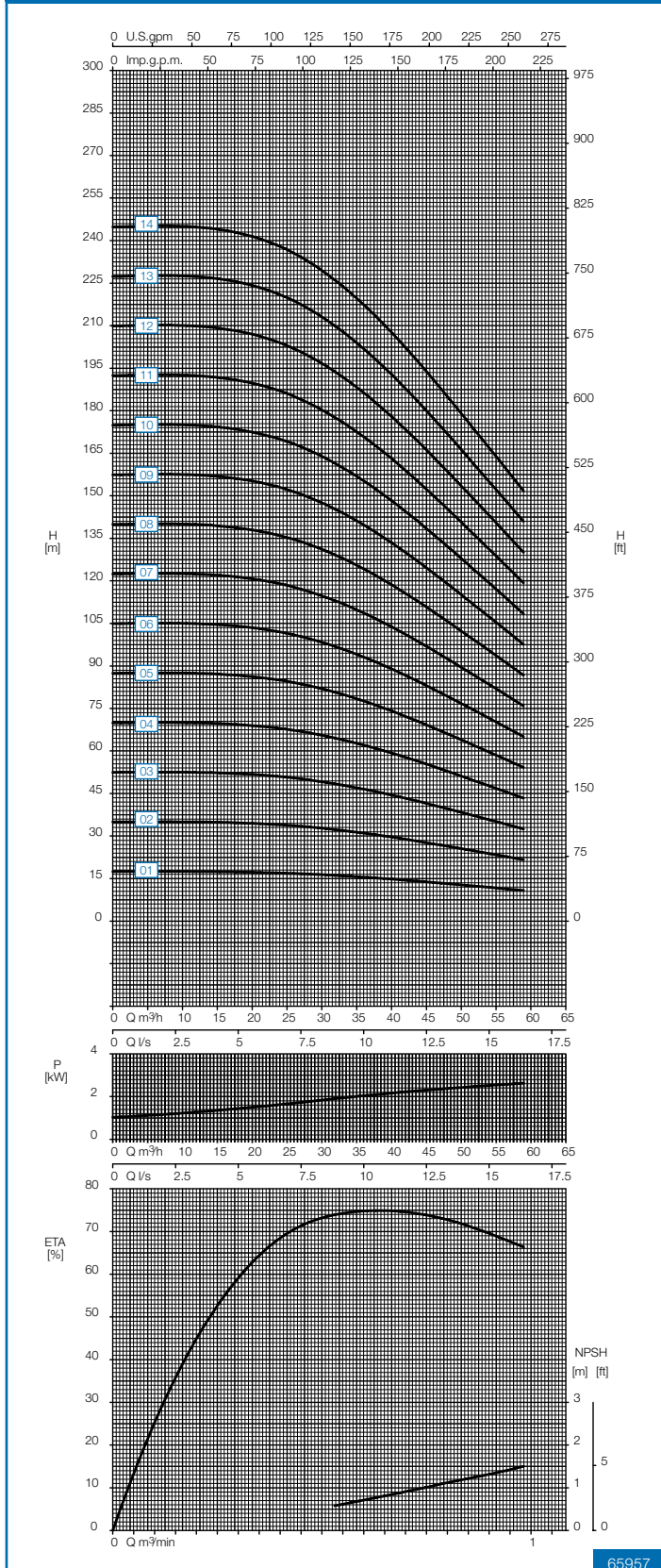

65957

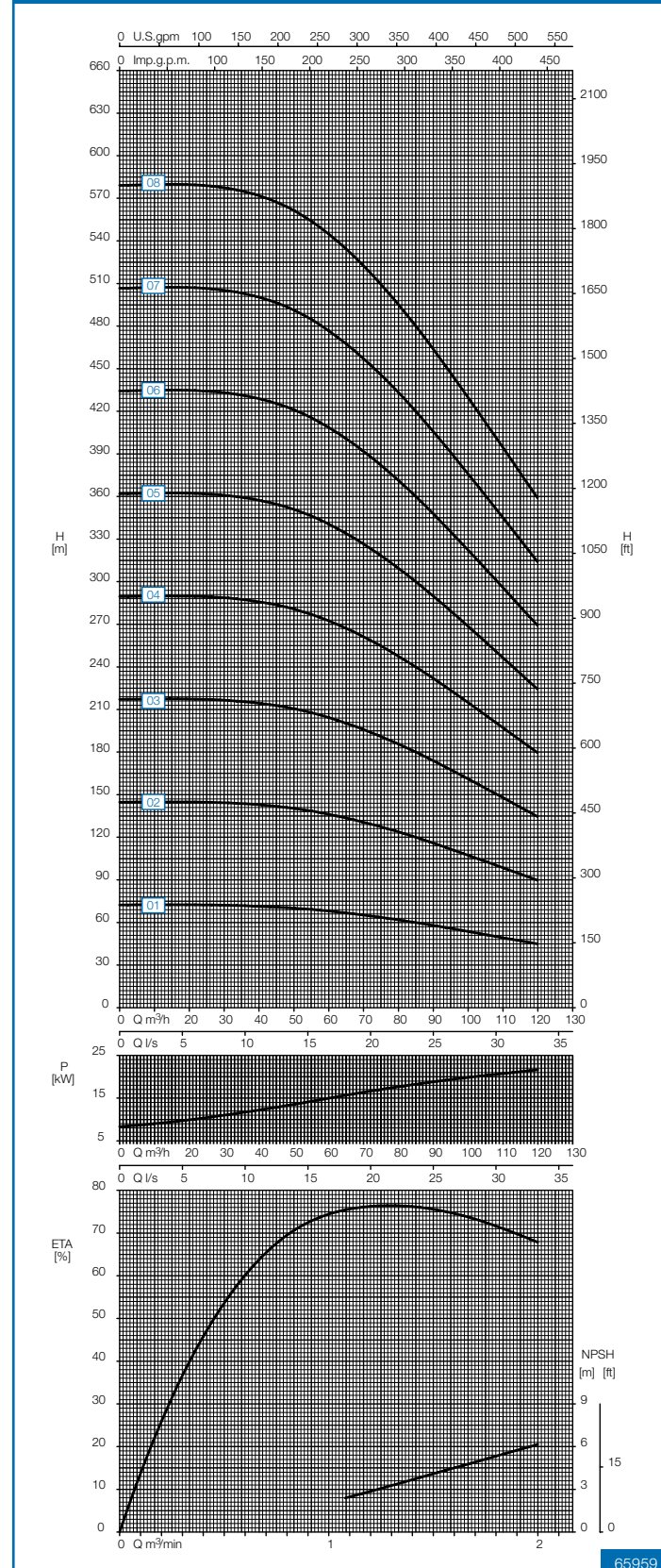

65959

Performance curve

Type 80-220.4

Notes to performance curves

- Curves valid according to DIN EN ISO 9906/2B.
- Power data refers to clean water, density 1 kg/dm³, viscosity 1 mm²/s.
- All duty points between the individual stage characteristics can be achieved by adapting the impeller diameters.

Speed 1450 rpm

Speed 2950 rpm

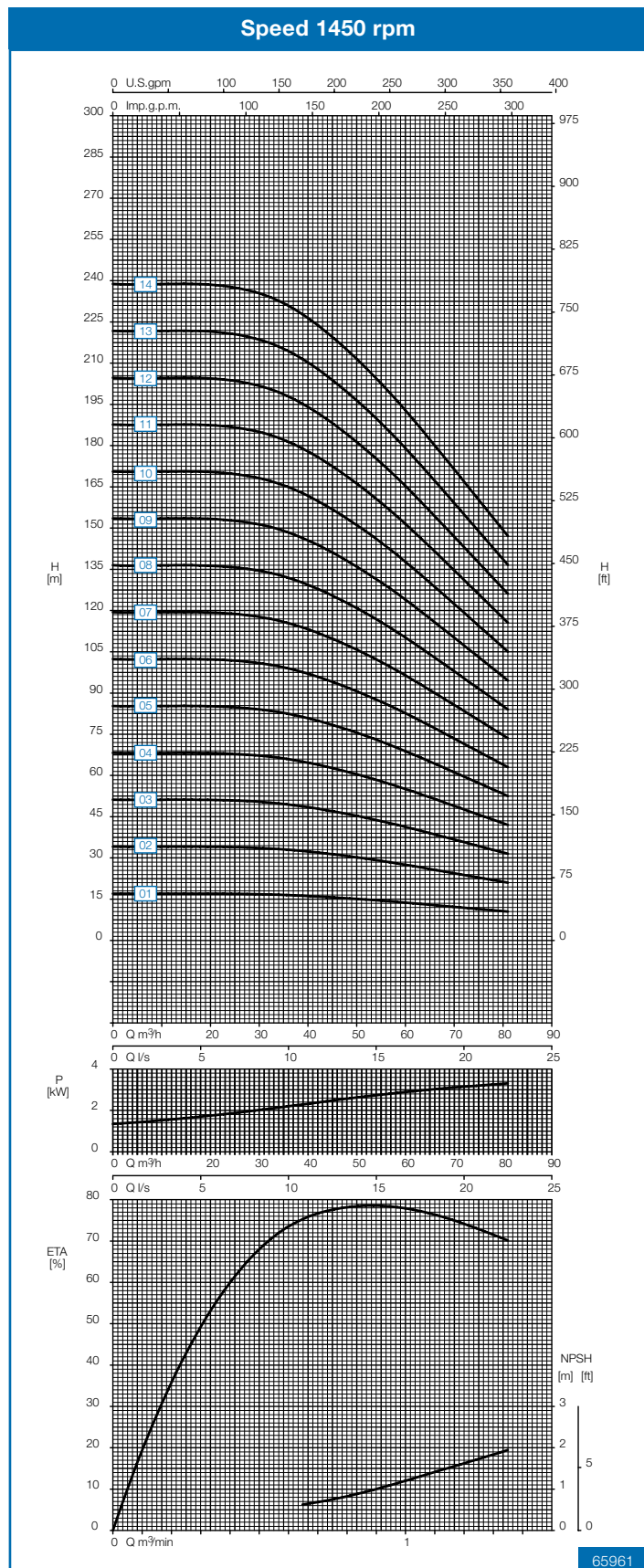

65961

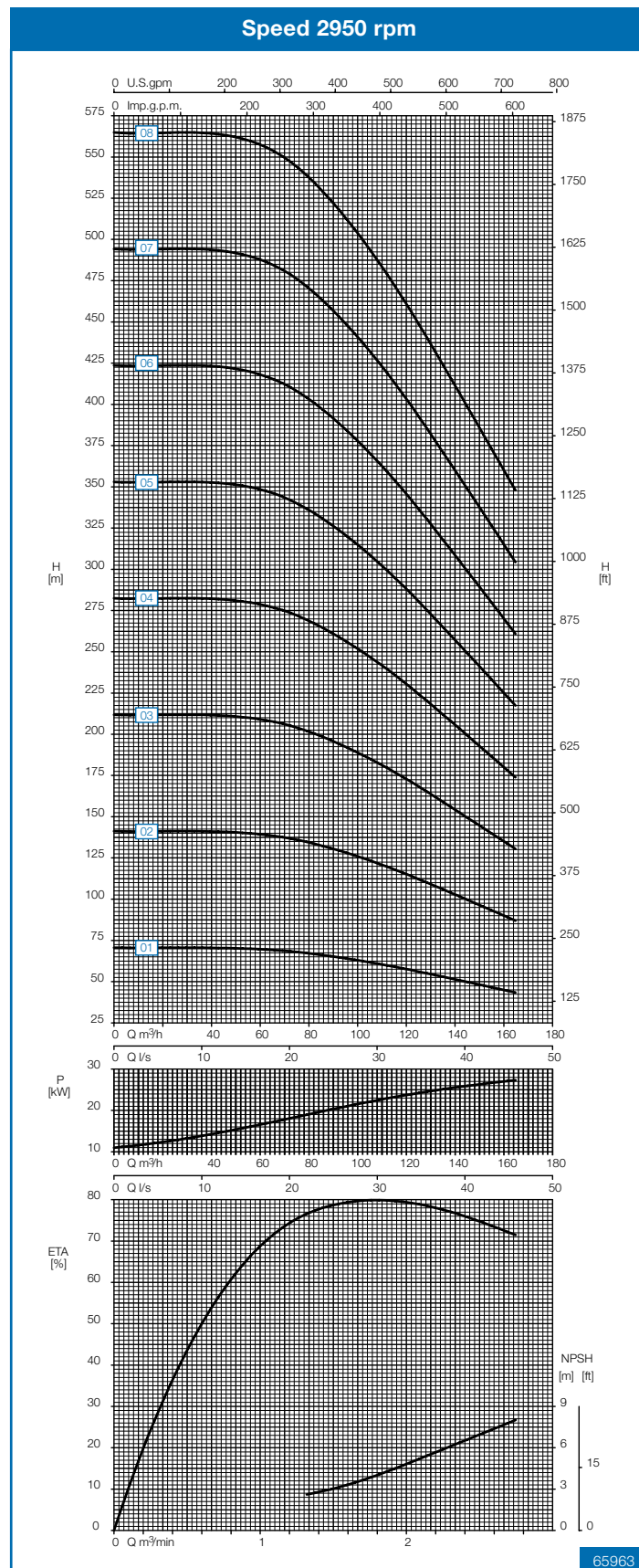

65963

Performance curve

Type 100-240.1

Notes to performance curves

- Curves valid according to DIN EN ISO 9906/2B.
- Power data refers to clean water, density 1 kg/dm³, viscosity 1 mm²/s.
- All duty points between the individual stage characteristics can be achieved by adapting the impeller diameters.

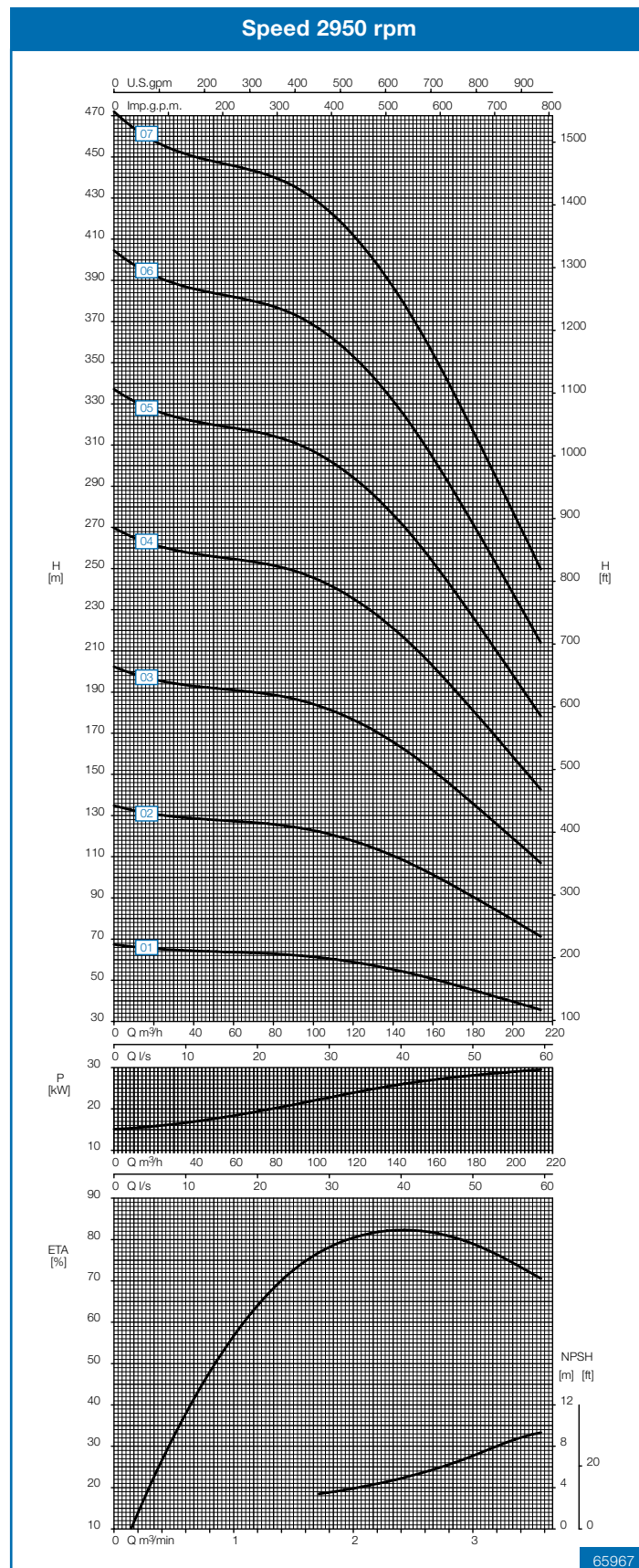
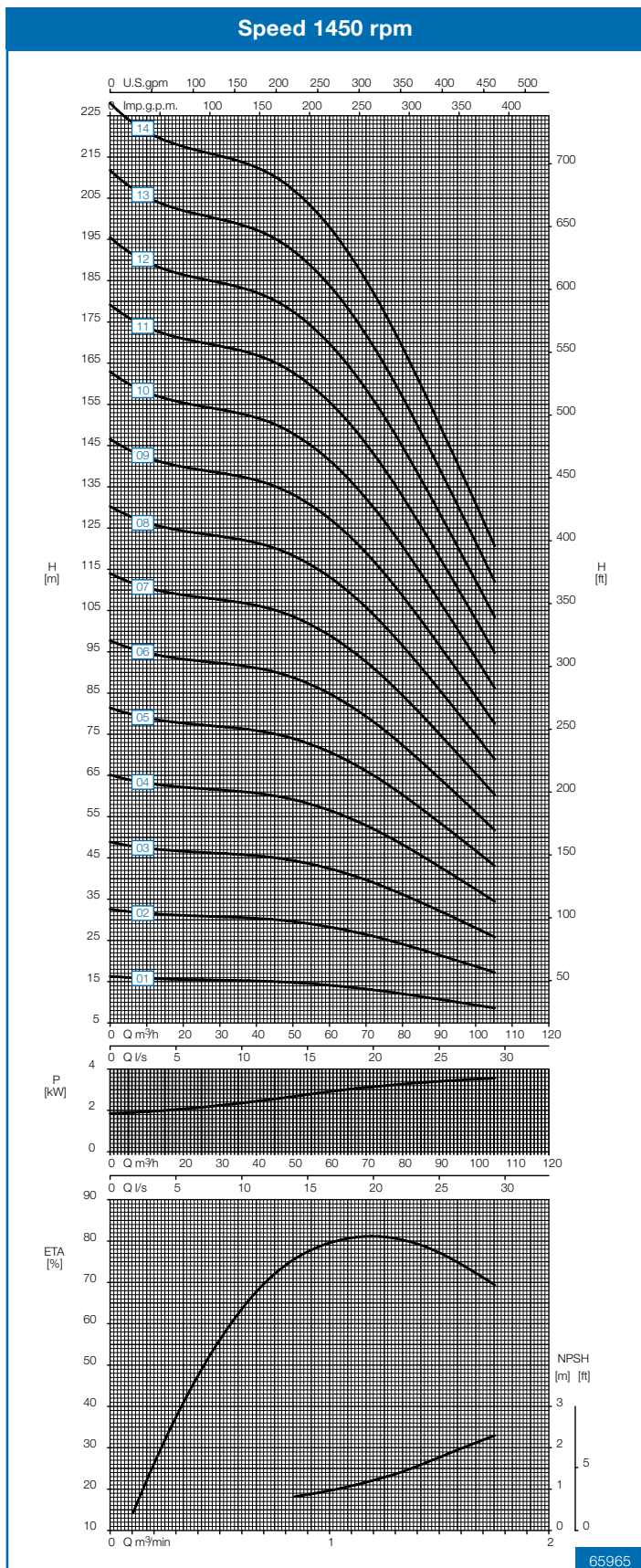

Performance curve

Type 100-240.2

Notes to performance curves

- Curves valid according to DIN EN ISO 9906/2B.
- Power data refers to clean water, density 1 kg/dm³, viscosity 1 mm²/s.
- All duty points between the individual stage characteristics can be achieved by adapting the impeller diameters.

Speed 1450 rpm

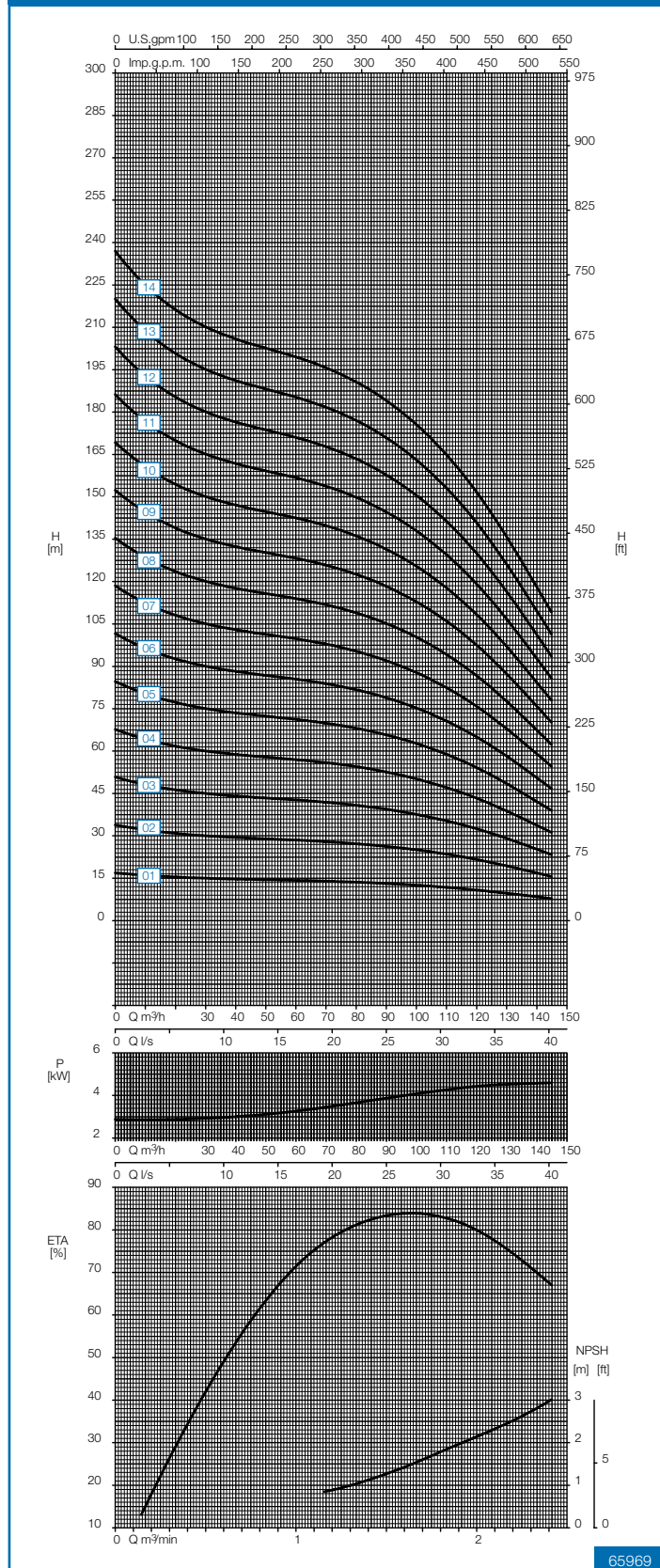

65969

Speed 2950 rpm

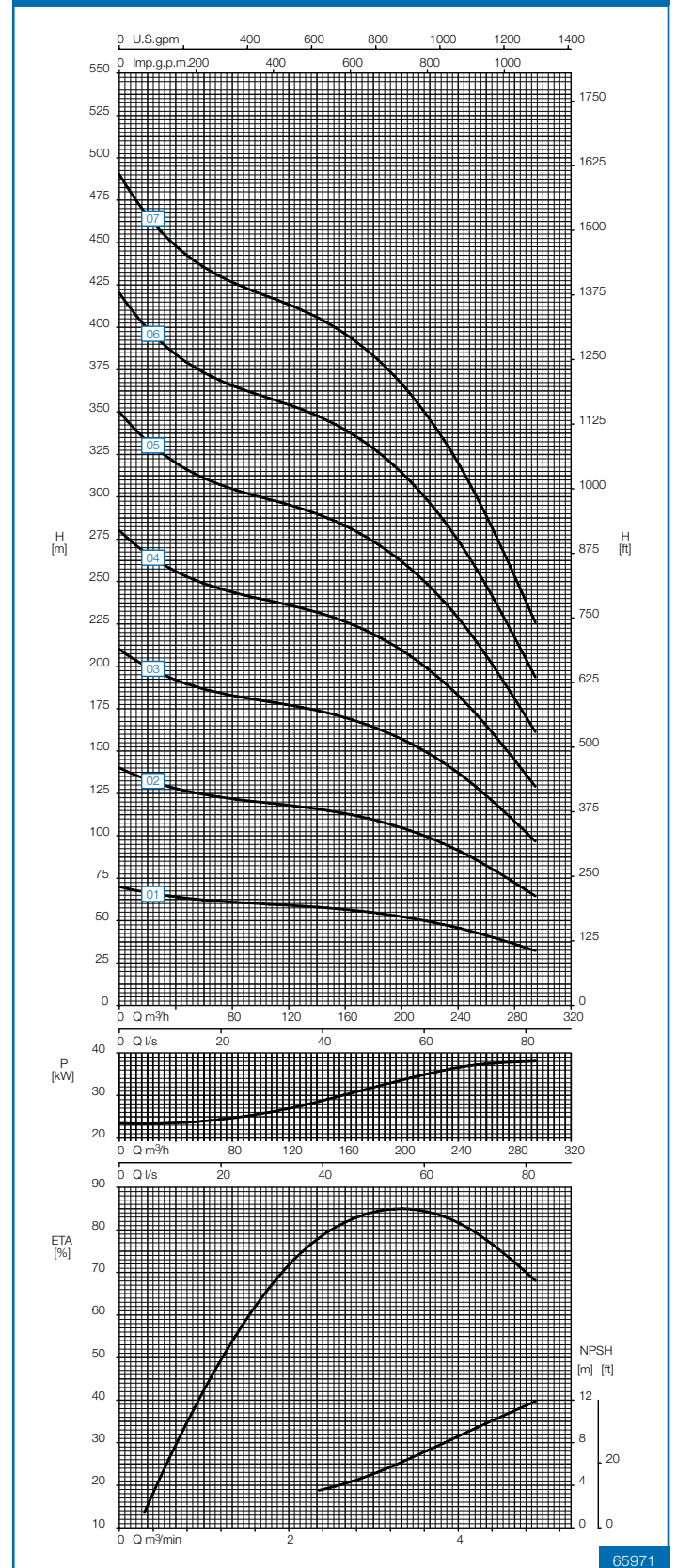

65971

Performance curve

Type 100-240.3

Notes to performance curves

- Curves valid according to DIN EN ISO 9906/2B.
- Power data refers to clean water, density 1 kg/dm³, viscosity 1 mm²/s.
- All duty points between the individual stage characteristics can be achieved by adapting the impeller diameters.

Speed 1450 rpm

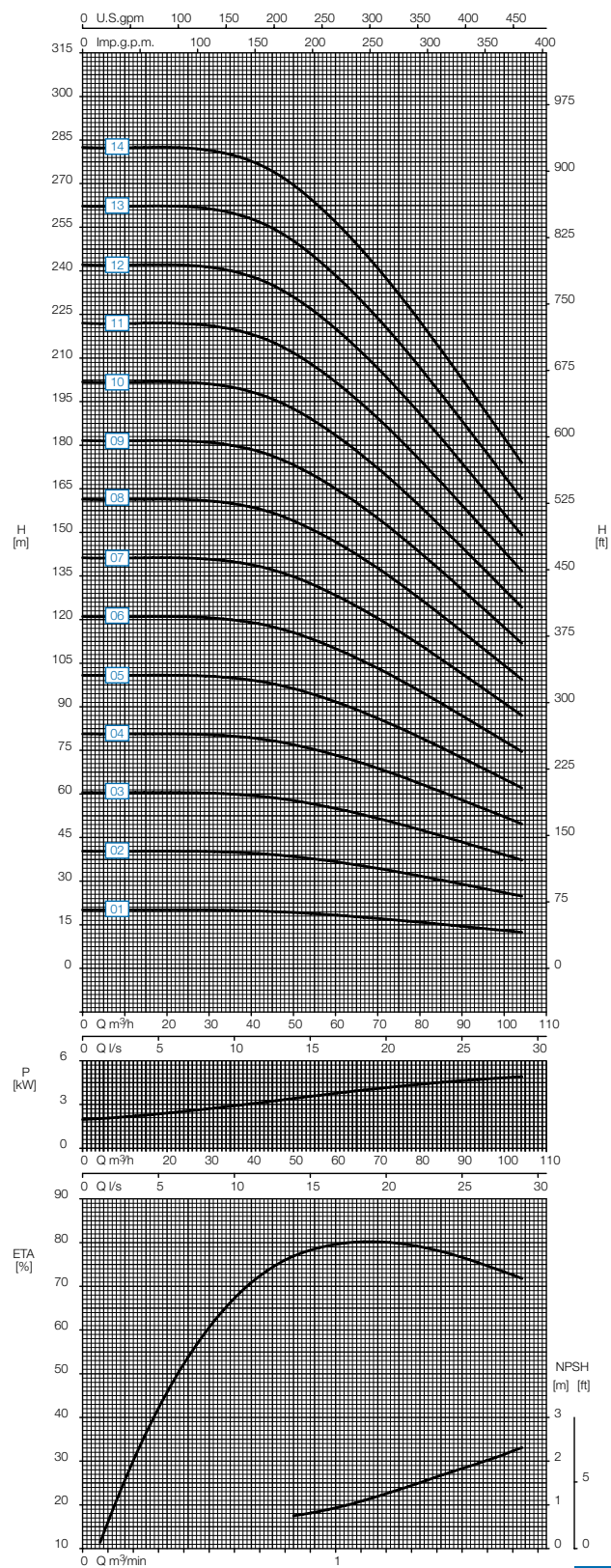

65973

Speed 2950 rpm

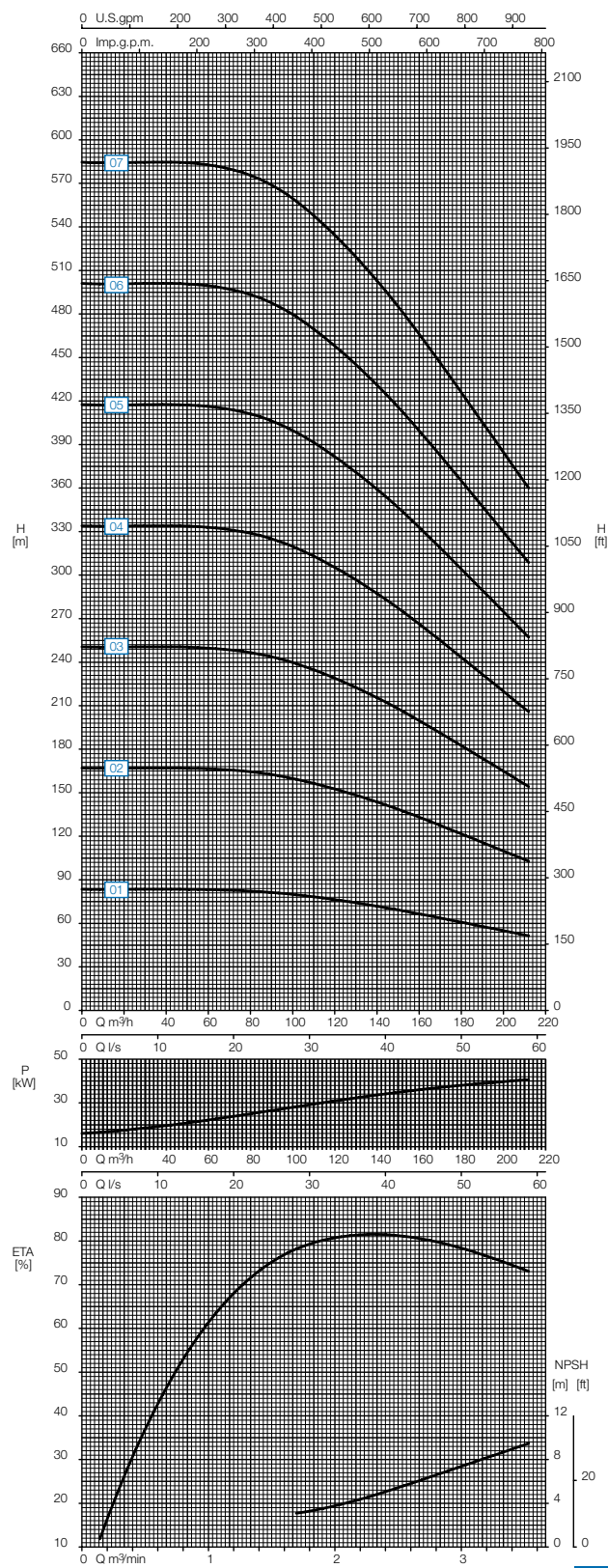

65975

Performance curve

Type 100-240.4

Notes to performance curves

- Curves valid according to DIN EN ISO 9906/2B.
- Power data refers to clean water, density 1 kg/dm³, viscosity 1 mm²/s.
- All duty points between the individual stage characteristics can be achieved by adapting the impeller diameters.

Speed 1450 rpm

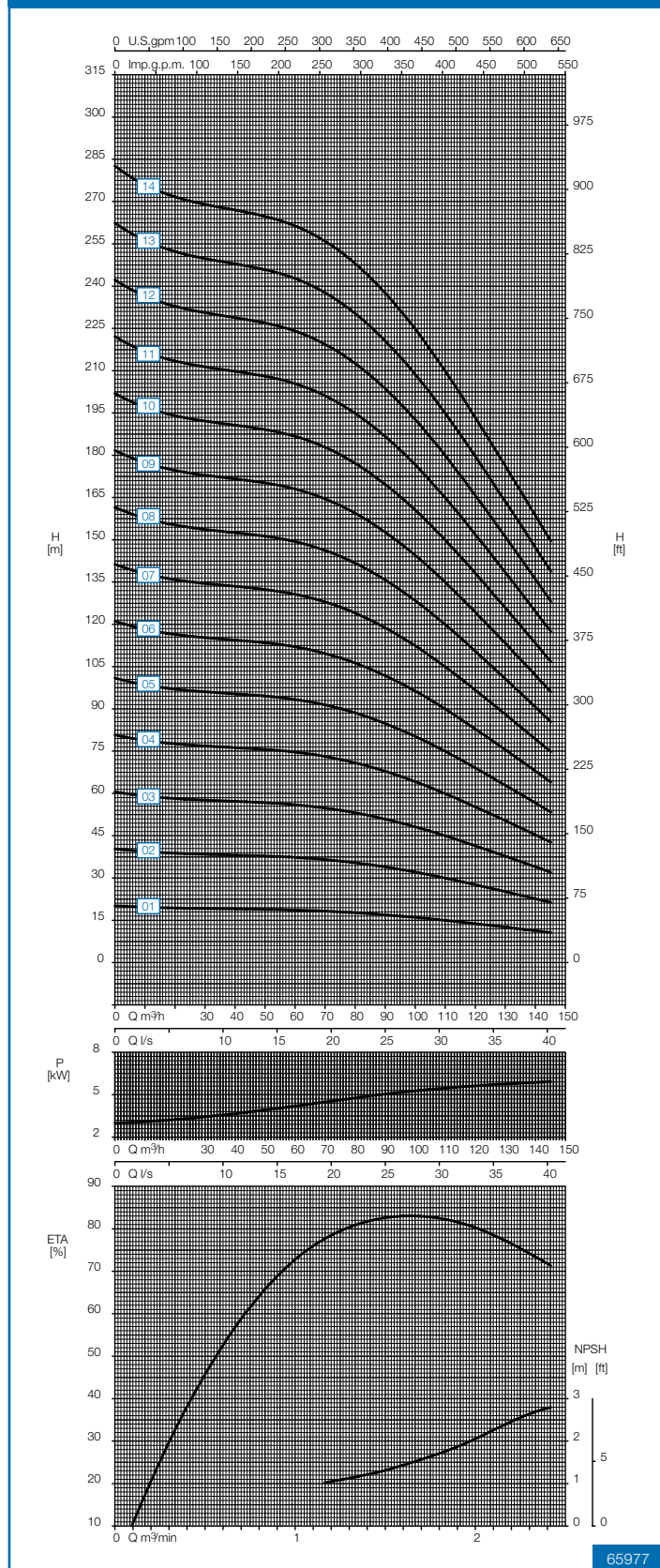

65977

Speed 2950 rpm

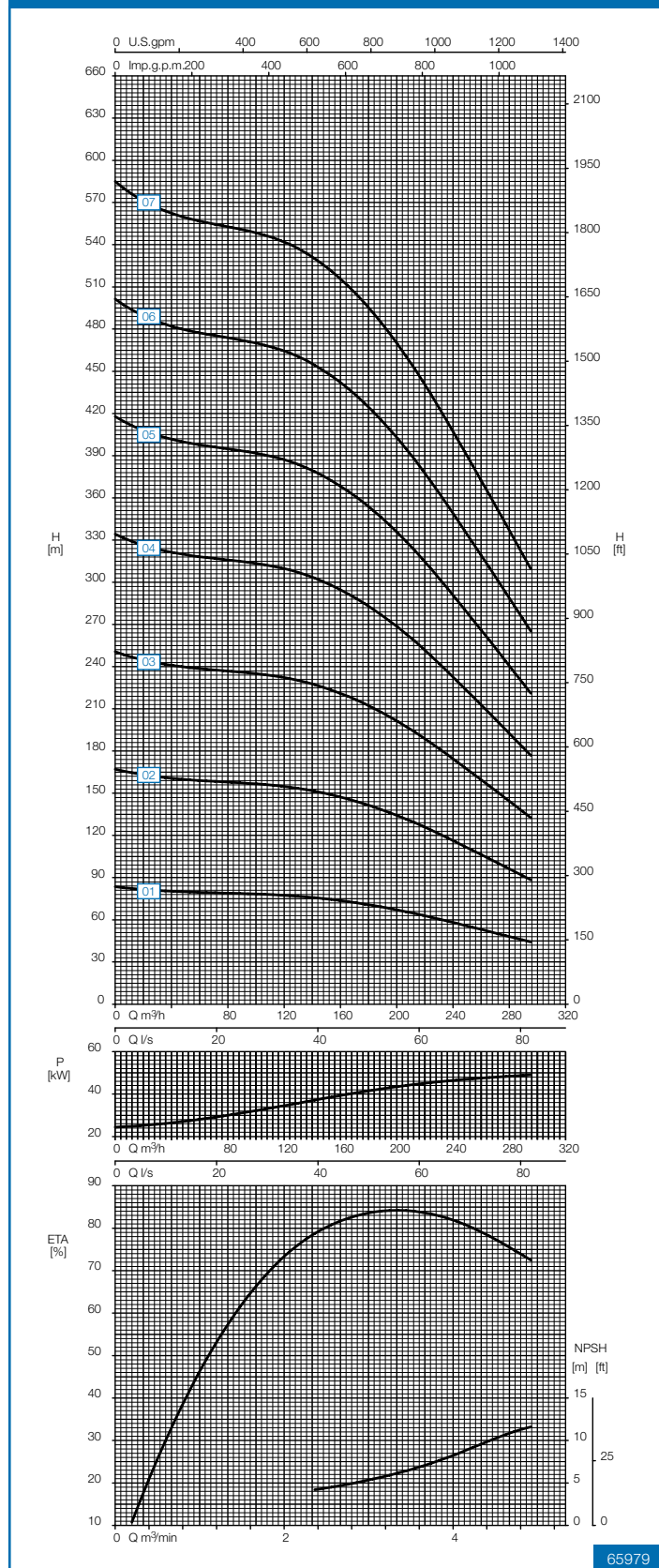

65979

Performance curve

Type 125-260.1

Notes to performance curves

- Curves valid according to DIN EN ISO 9906/2B.
- Power data refers to clean water, density 1 kg/dm³, viscosity 1 mm²/s.
- All duty points between the individual stage characteristics can be achieved by adapting the impeller diameters.

Speed 1450 rpm

Speed 2950 rpm

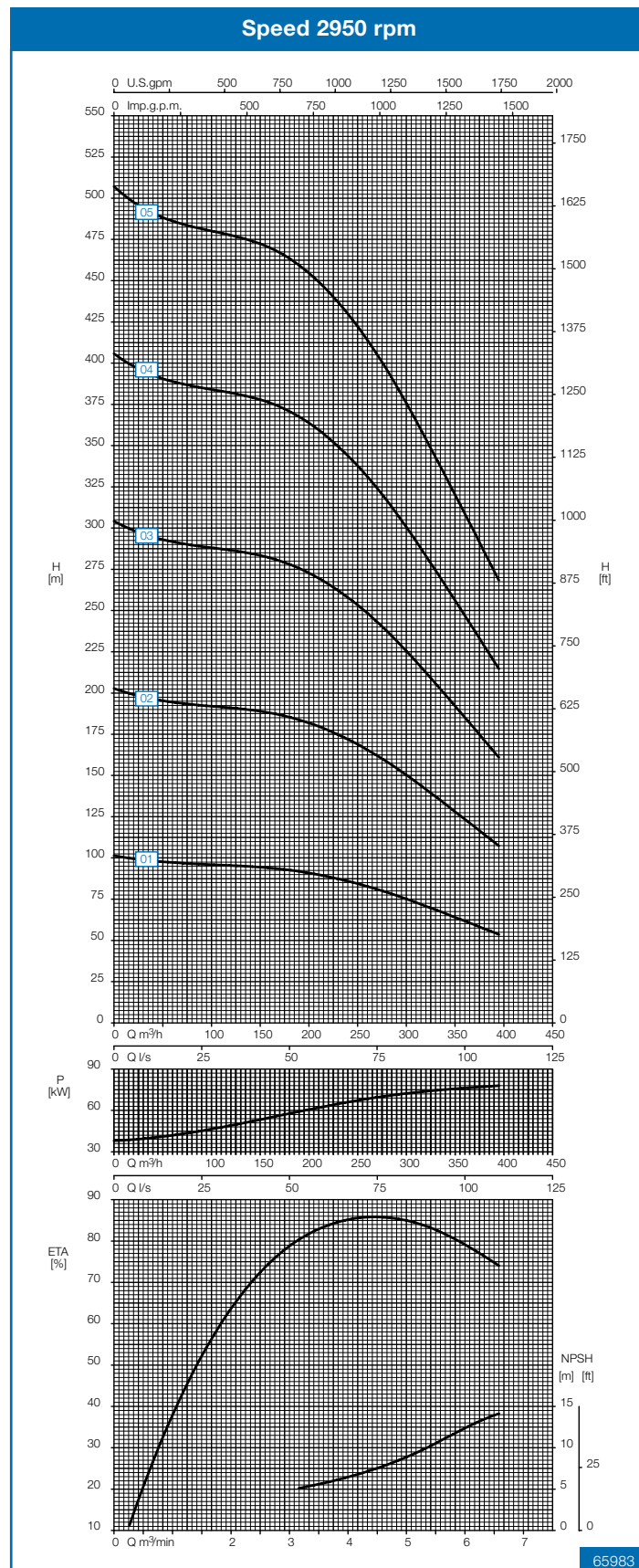
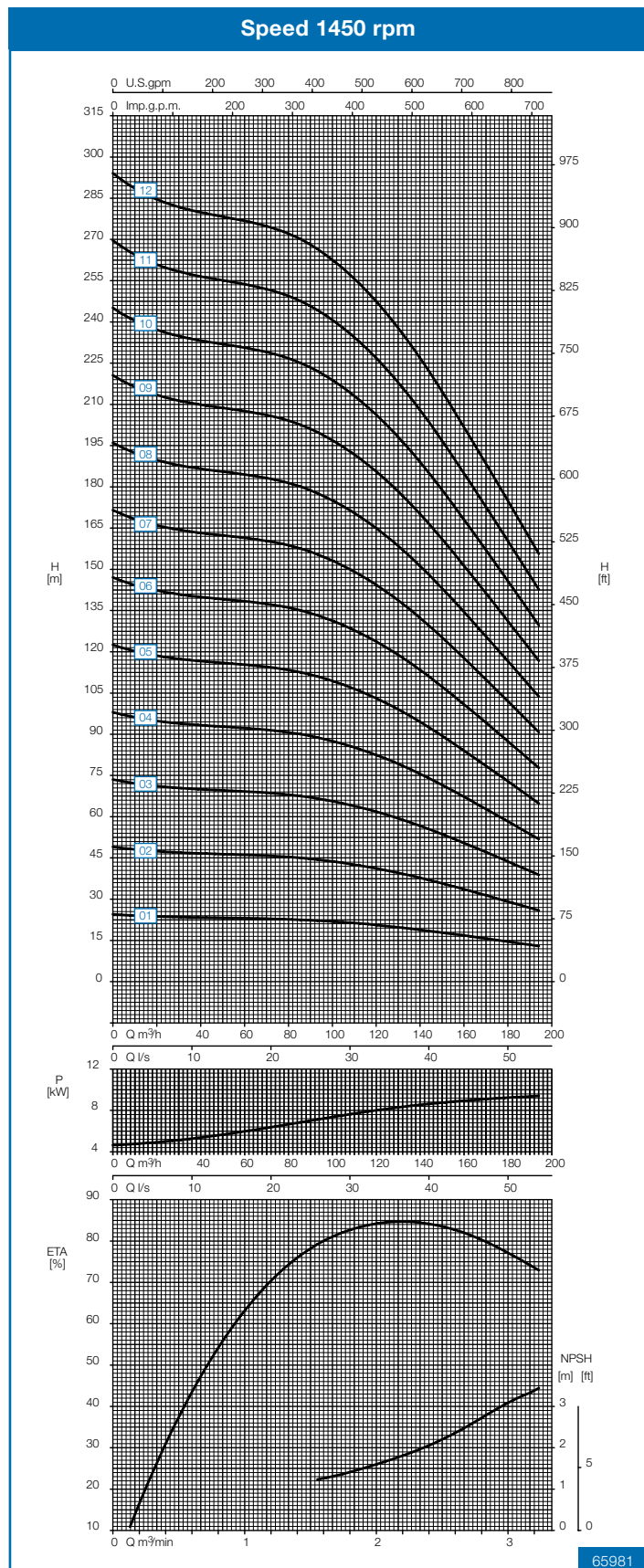

Performance curve

Type 125-260.2

Notes to performance curves

- Curves valid according to DIN EN ISO 9906/2B.
- Power data refers to clean water, density 1 kg/dm³, viscosity 1 mm²/s.
- All duty points between the individual stage characteristics can be achieved by adapting the impeller diameters.

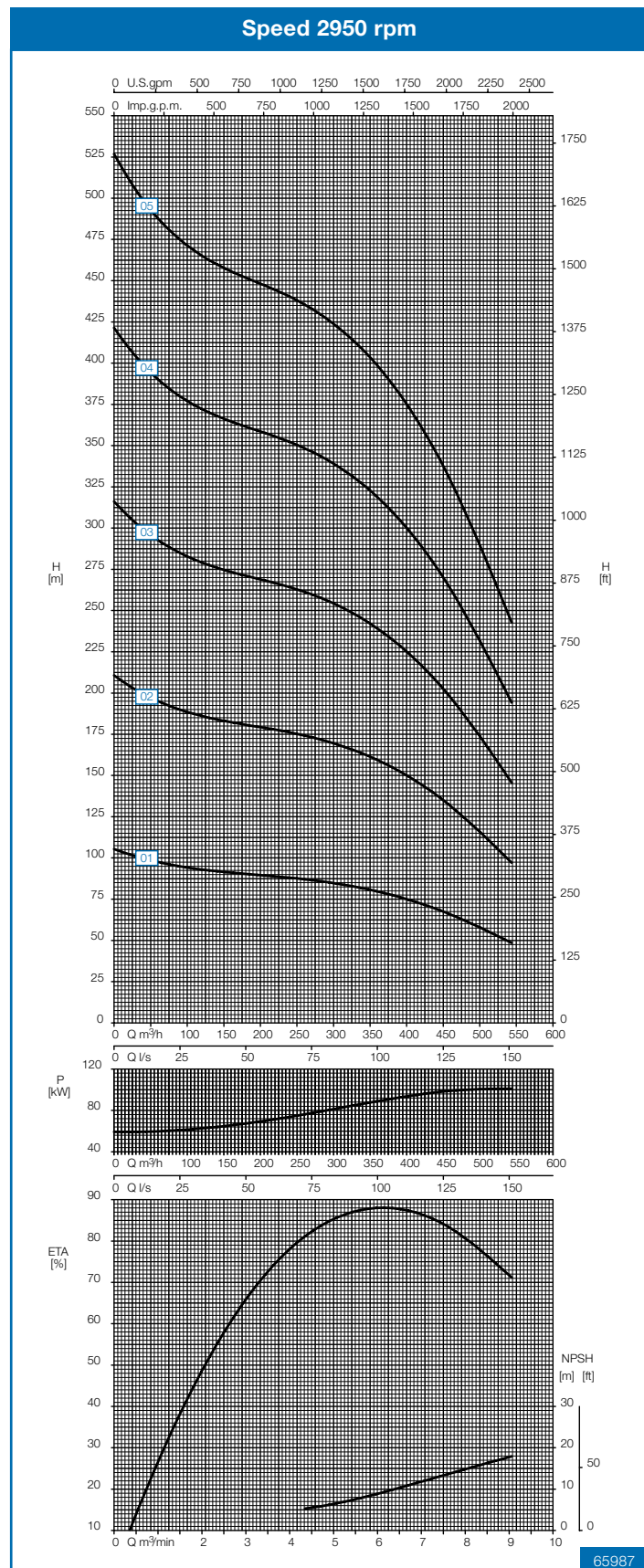
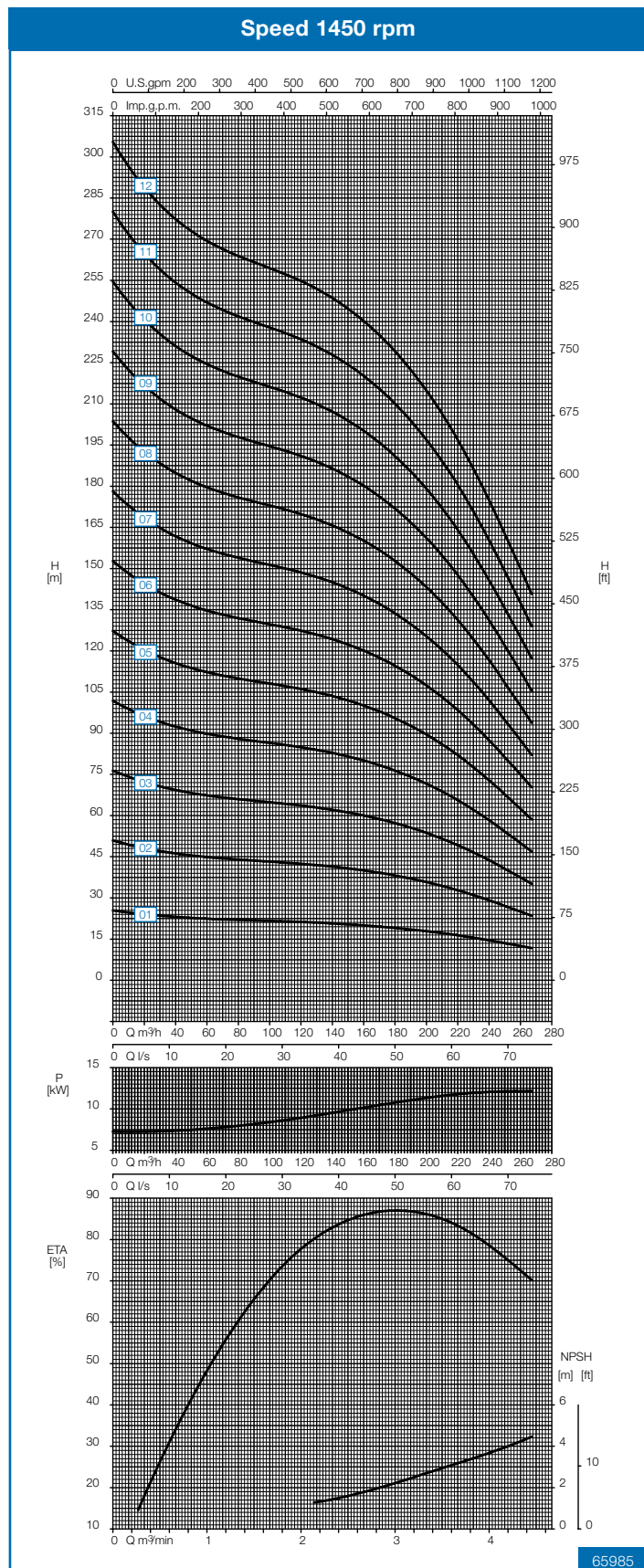

Performance curve

Type 150-305.1

Notes to performance curves

- Curves valid according to DIN EN ISO 9906/2B.
- Power data refers to clean water, density 1 kg/dm³, viscosity 1 mm²/s.
- All duty points between the individual stage characteristics can be achieved by adapting the impeller diameters.

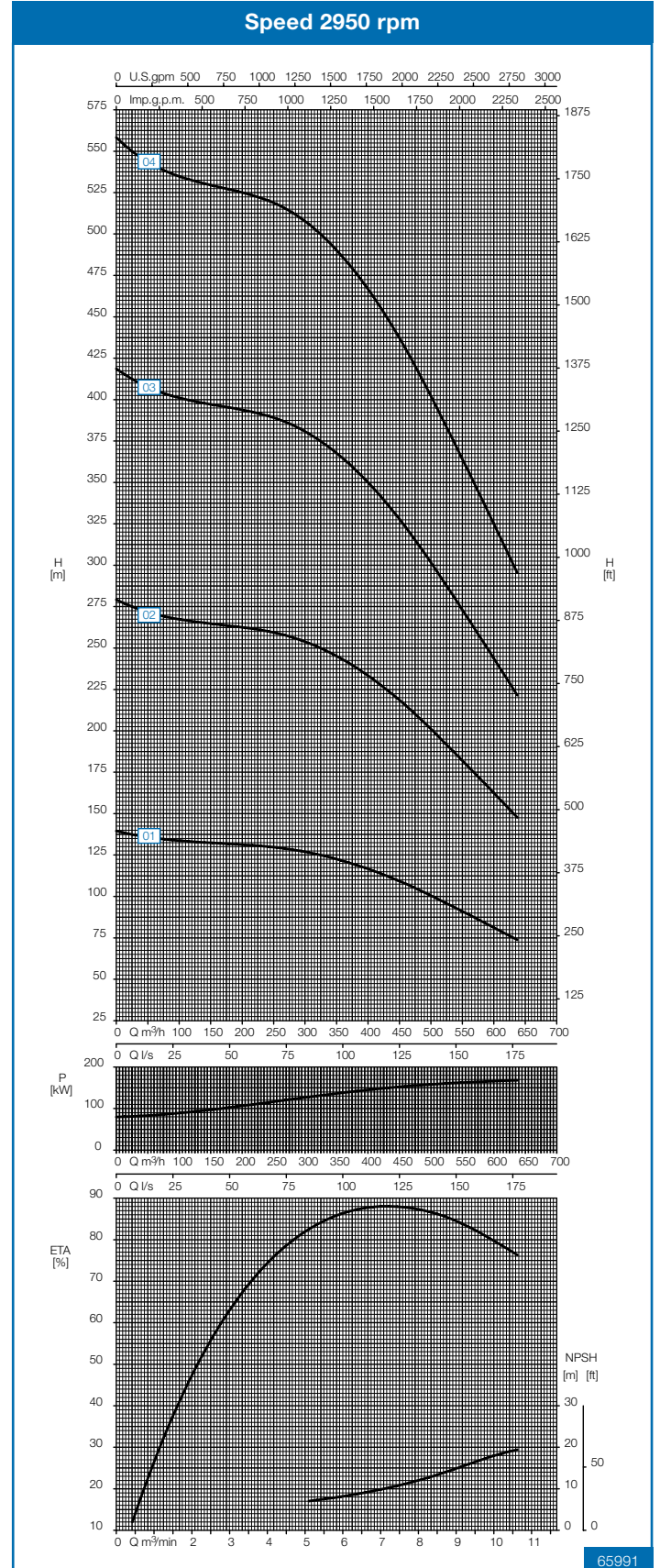
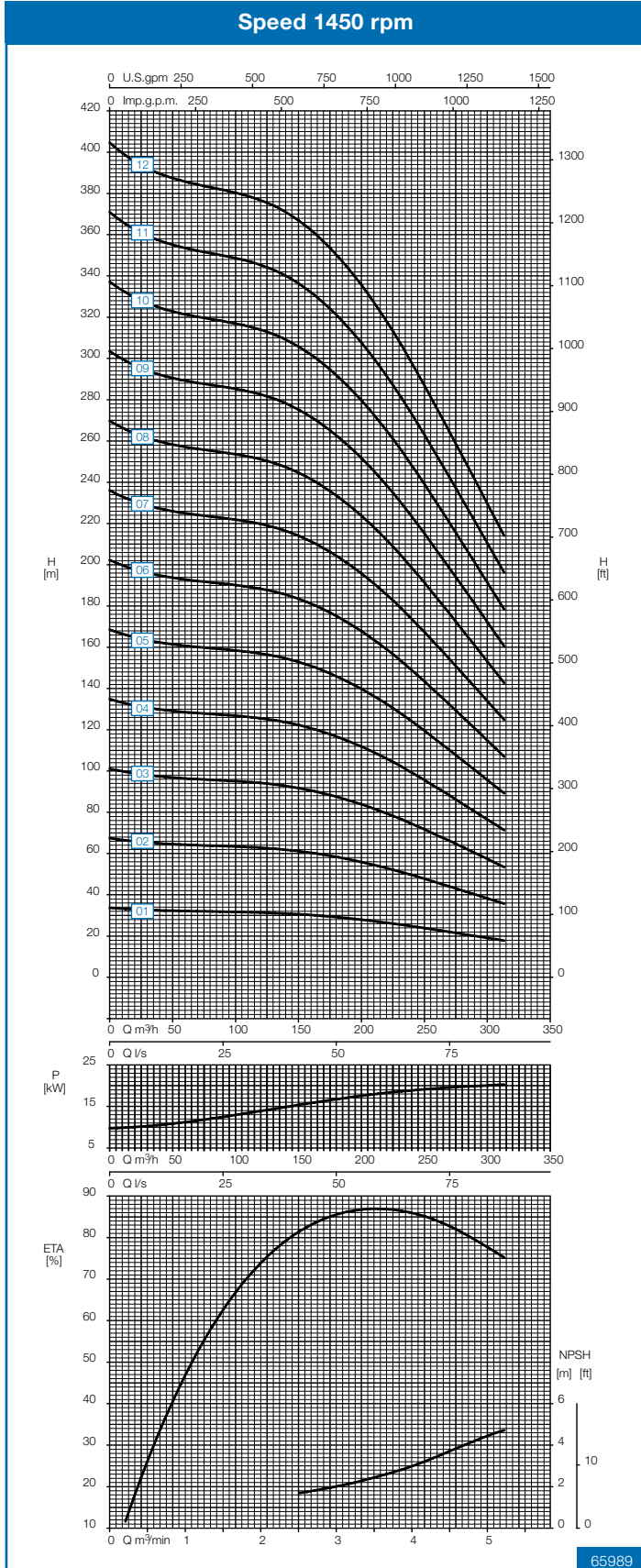

Performance curve

Type 150-305.2

Notes to performance curves

- Curves valid according to DIN EN ISO 9906/2B.
- Power data refers to clean water, density 1 kg/dm³, viscosity 1 mm²/s.
- All duty points between the individual stage characteristics can be achieved by adapting the impeller diameters.

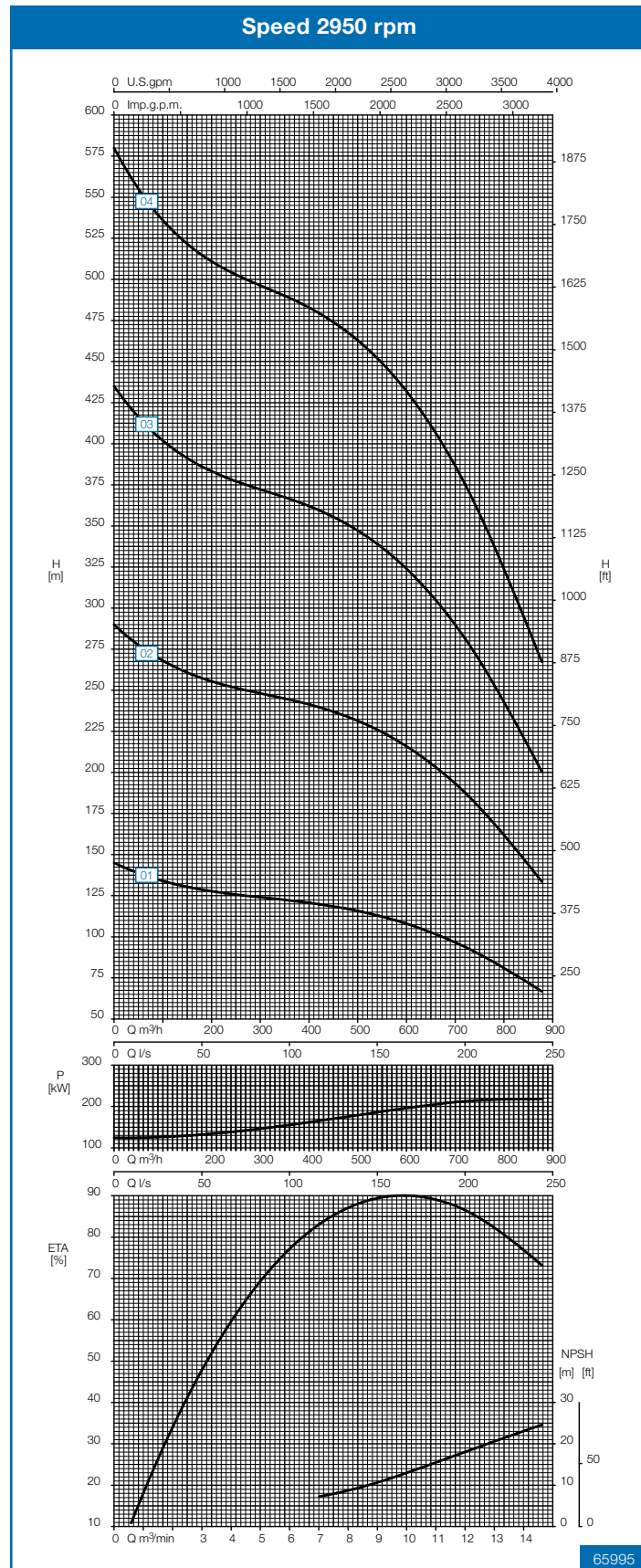
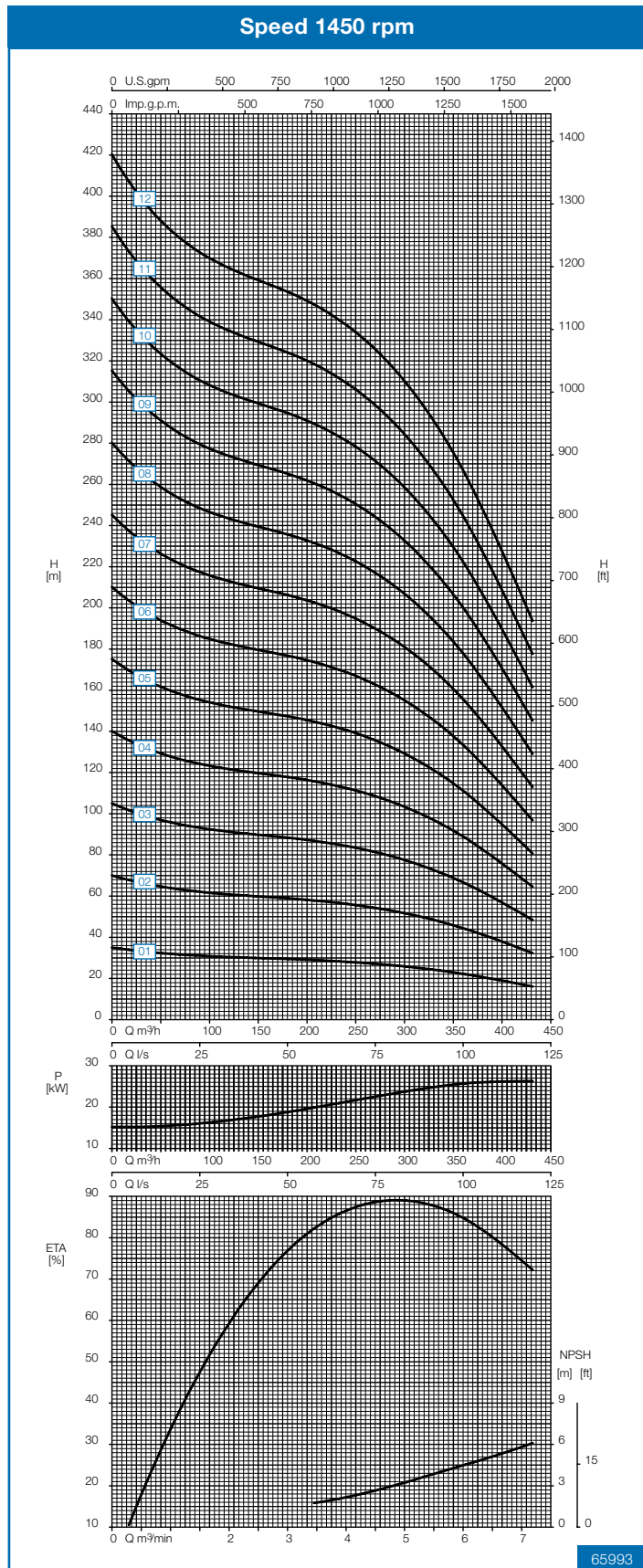

Performance curve

Type 200-360.1

Notes to performance curves

- Curves valid according to DIN EN ISO 9906/2B.
- Power data refers to clean water, density 1 kg/dm³, viscosity 1 mm²/s.
- All duty points between the individual stage characteristics can be achieved by adapting the impeller diameters.

Speed 980 rpm

Speed 1450 rpm

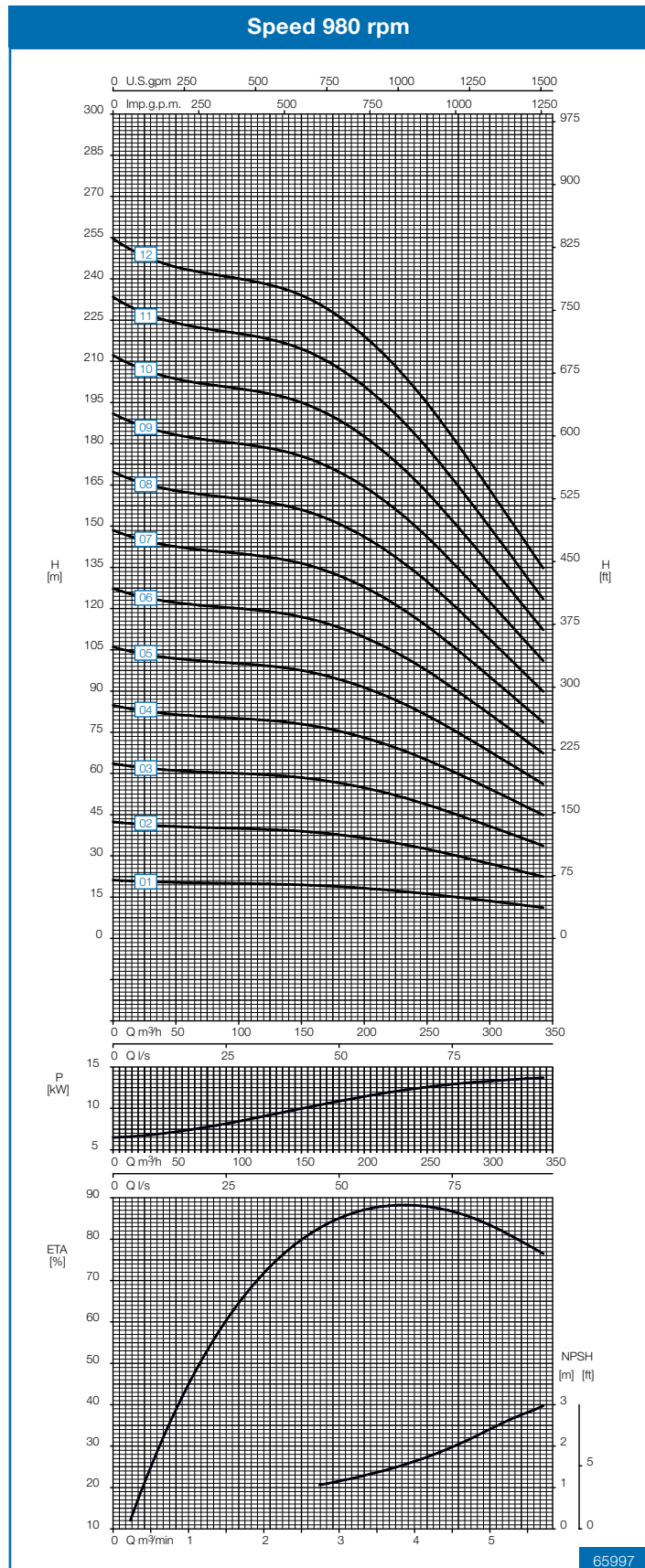

65997

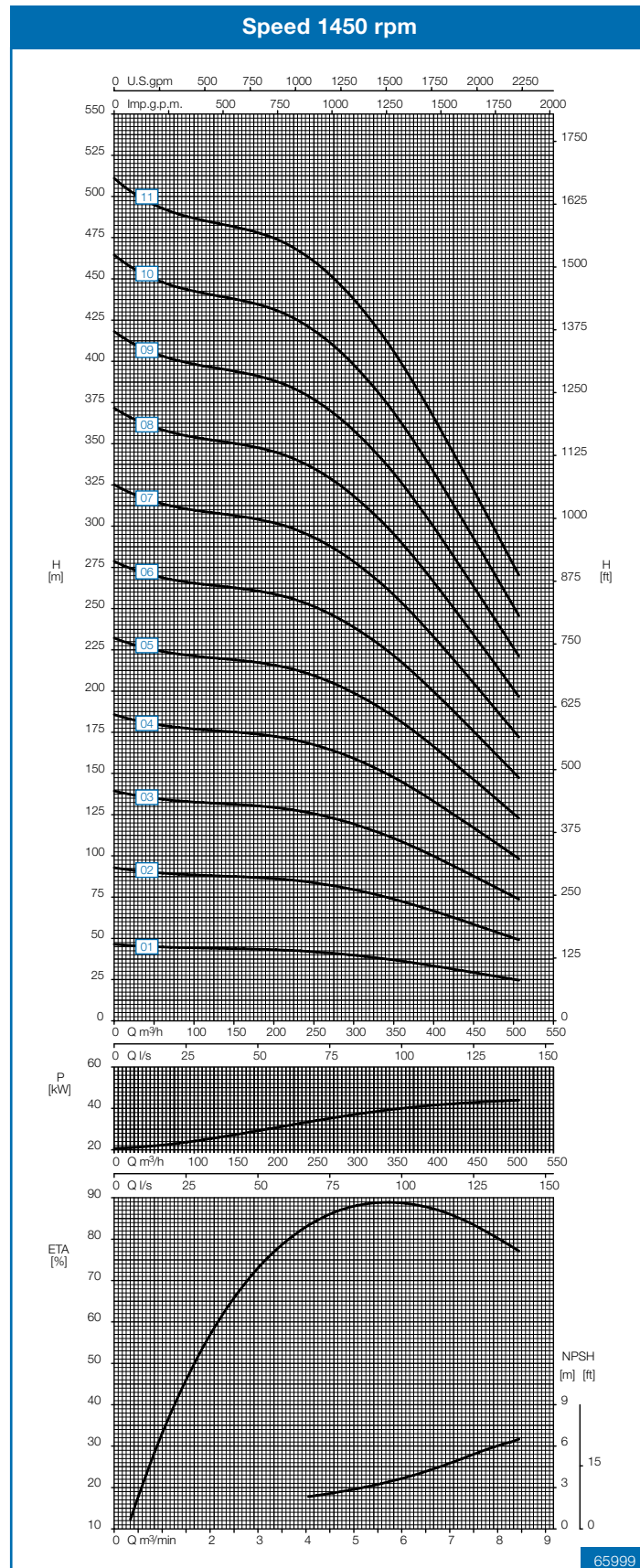

65999

Performance curve

Type 200-360.2

Notes to performance curves

- Curves valid according to DIN EN ISO 9906/2B.
- Power data refers to clean water, density 1 kg/dm³, viscosity 1 mm²/s.
- All duty points between the individual stage characteristics can be achieved by adapting the impeller diameters.

Speed 980 rpm

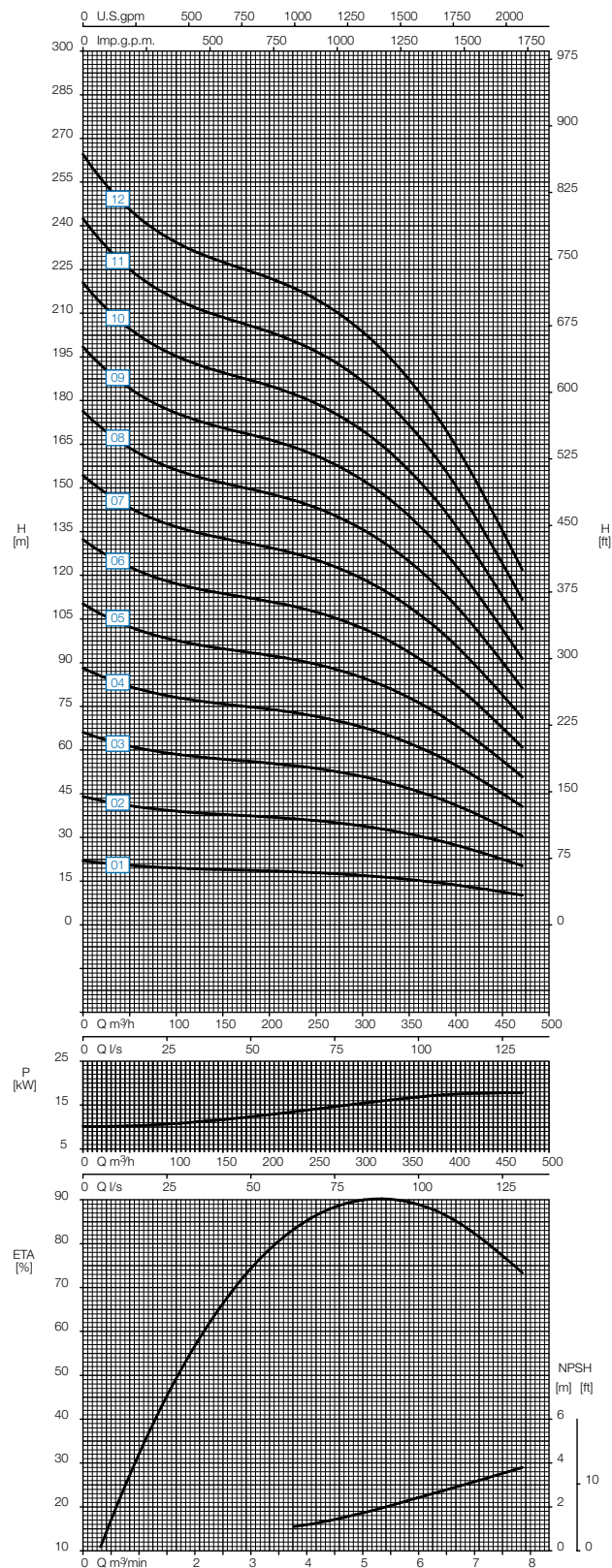

66001

Speed 1450 rpm

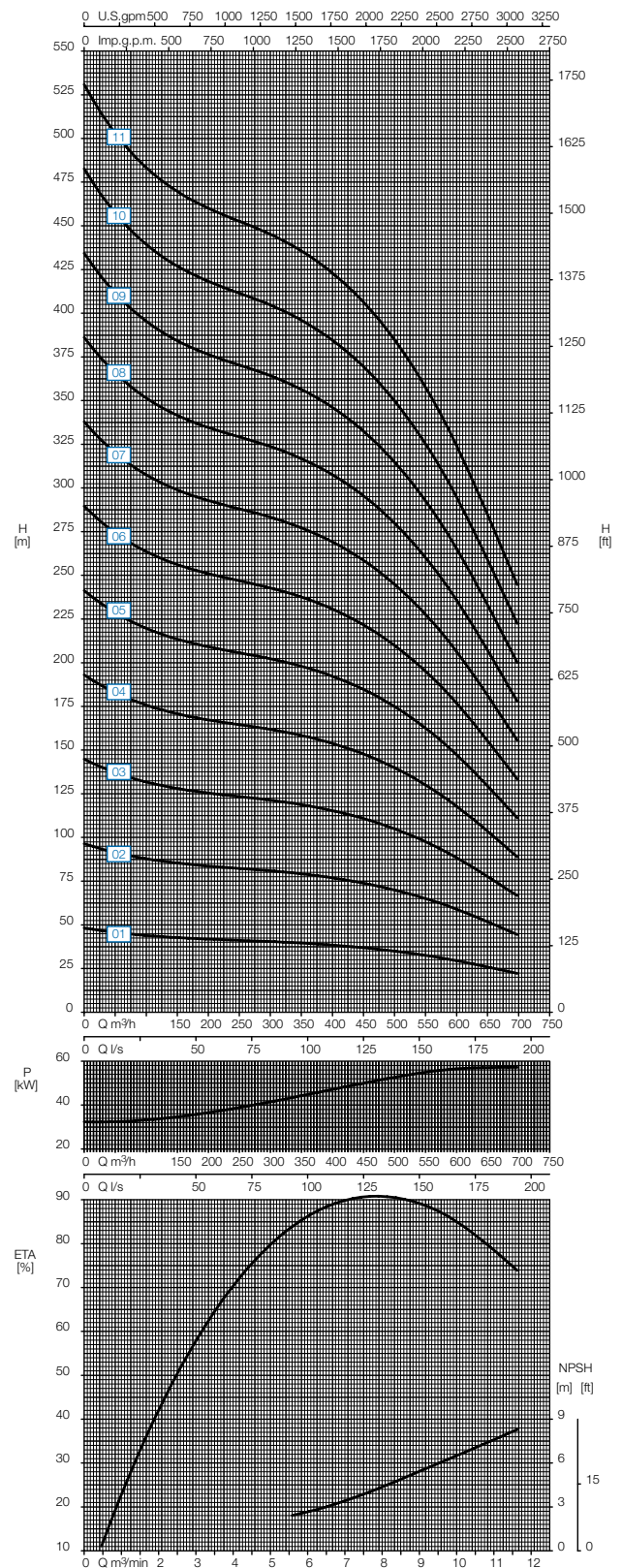

66003

Performance curve

Type 40-160.1

Notes to performance curves

- Curves valid according to DIN EN ISO 9906/2B.
- Power data refers to clean water, density 1 kg/dm³, viscosity 1 mm²/s.
- All duty points between the individual stage characteristics can be achieved by adapting the impeller diameters.

Speed 1760 rpm

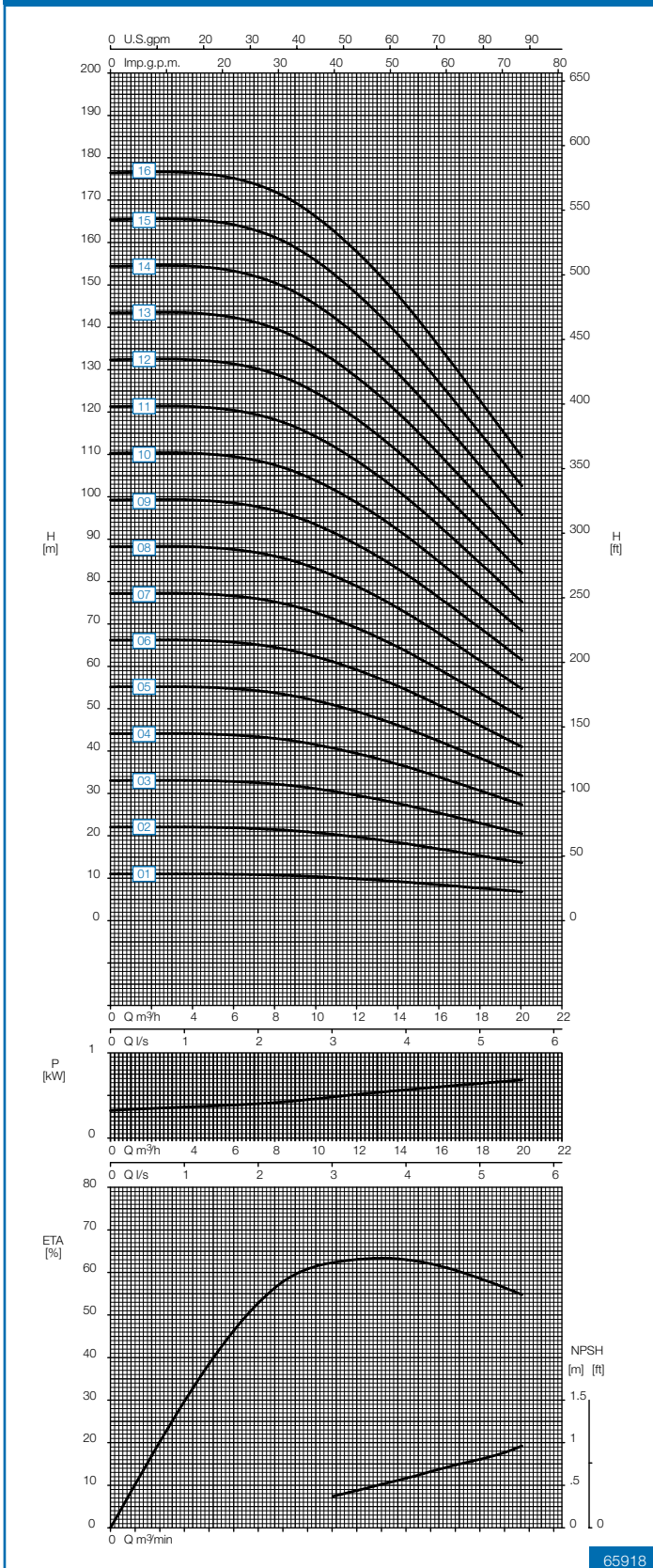

65918

Speed 3600 rpm

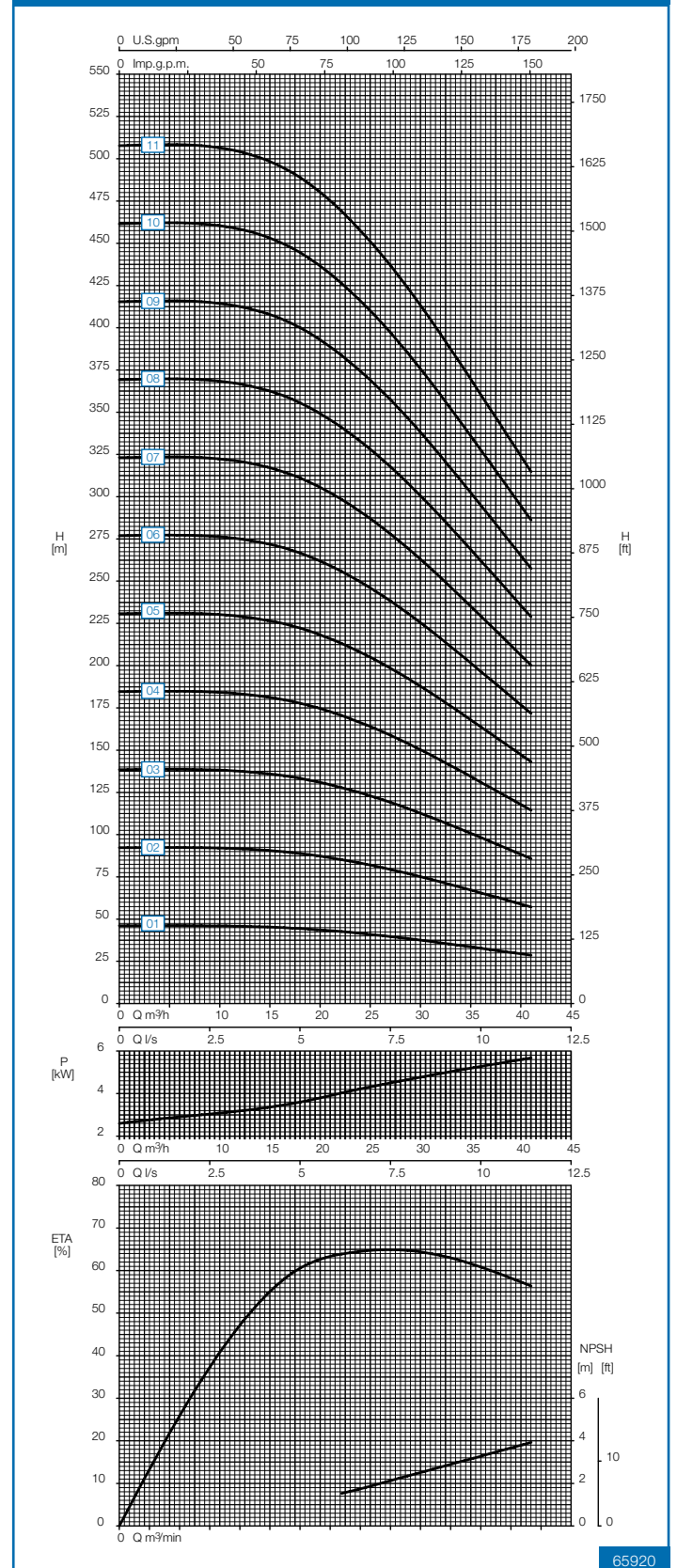

65920

Performance curve

Type 40-160.2

Notes to performance curves

- Curves valid according to DIN EN ISO 9906/2B.
- Power data refers to clean water, density 1 kg/dm³, viscosity 1 mm²/s.
- All duty points between the individual stage characteristics can be achieved by adapting the impeller diameters.

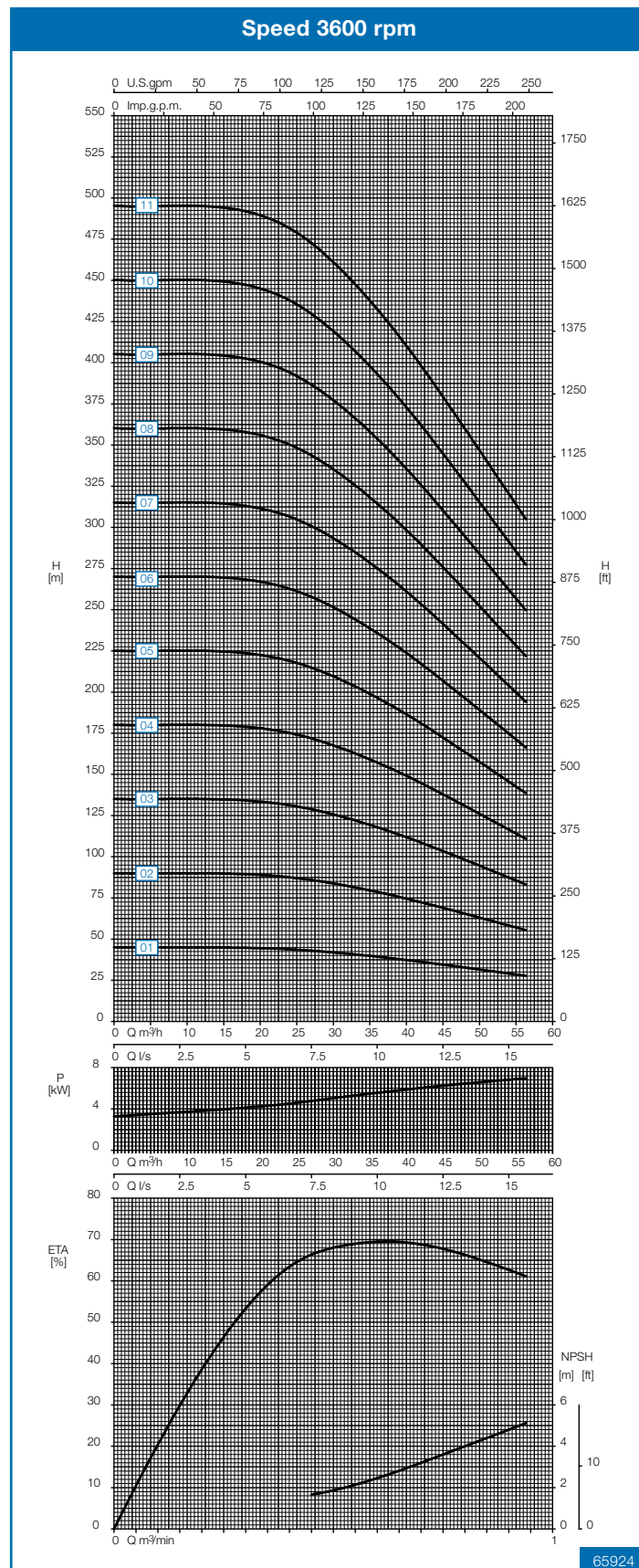
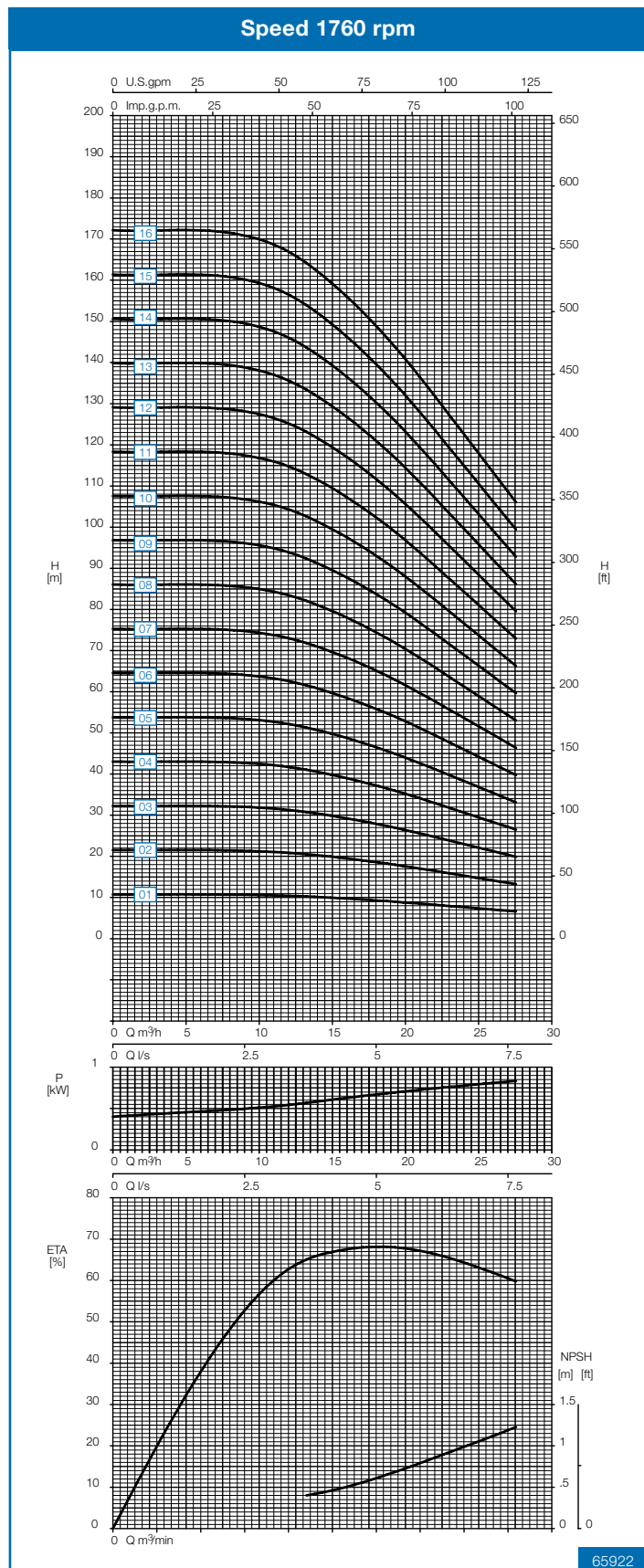

Performance curve

Type 40-160.3

Notes to performance curves

- Curves valid according to DIN EN ISO 9906/2B.
- Power data refers to clean water, density 1 kg/dm³, viscosity 1 mm²/s.
- All duty points between the individual stage characteristics can be achieved by adapting the impeller diameters.

Speed 1760 rpm

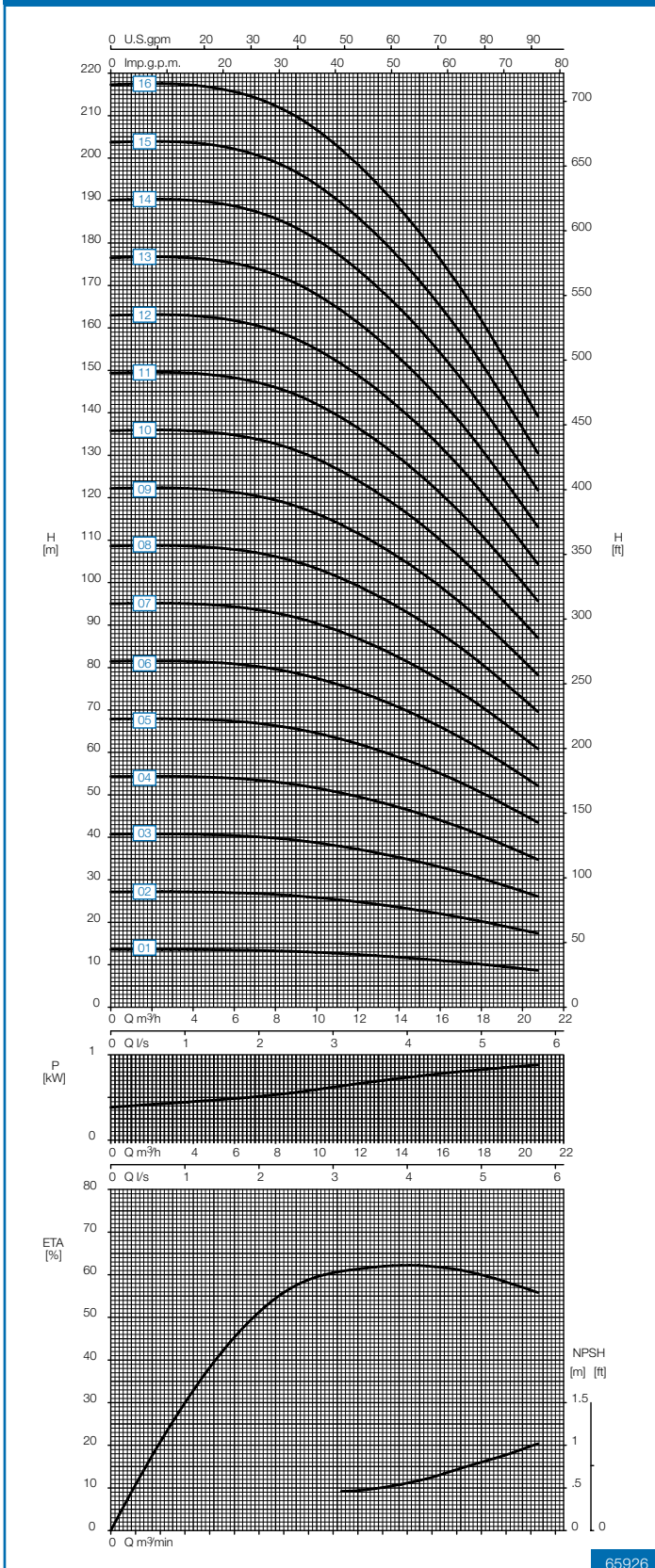

65926

Speed 3600 rpm

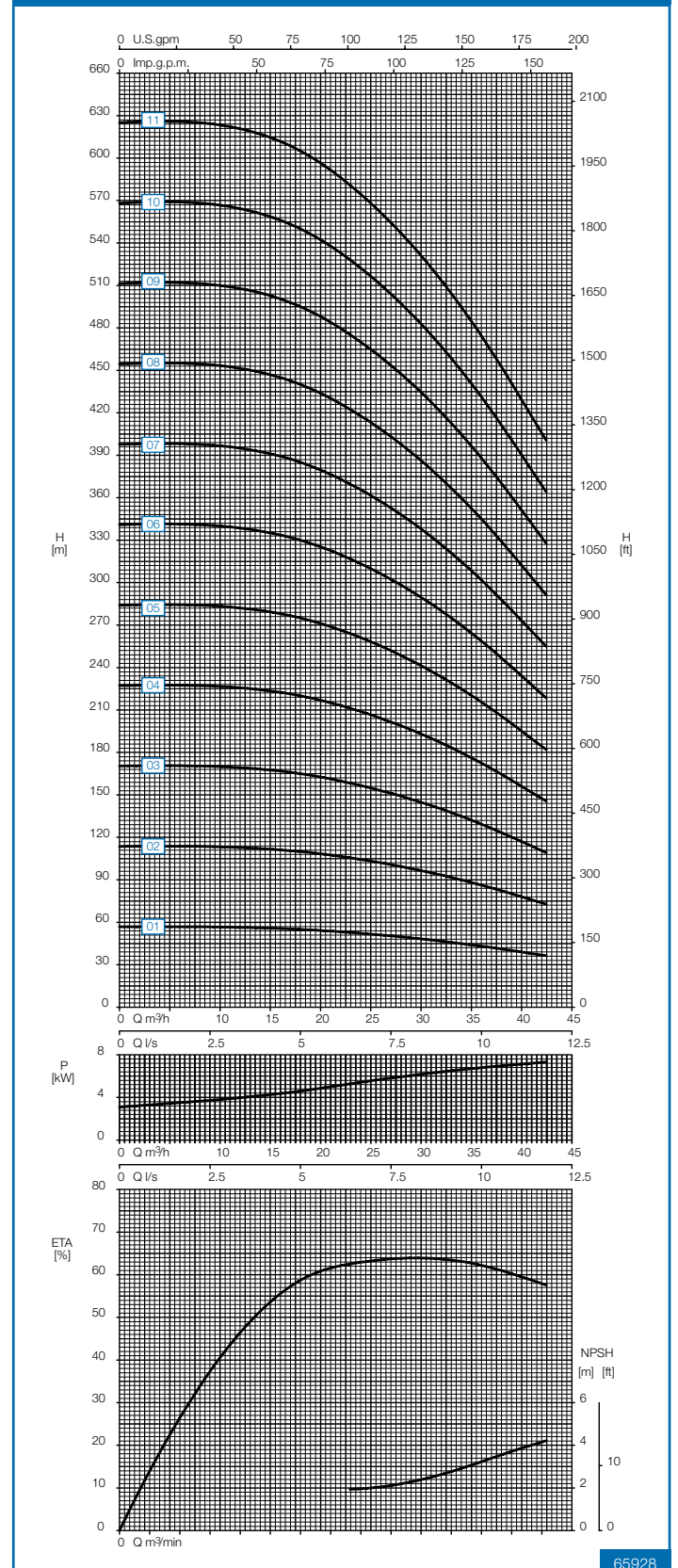

65928

Performance curve

Type 40-160.4

Notes to performance curves

- Curves valid according to DIN EN ISO 9906/2B.
- Power data refers to clean water, density 1 kg/dm³, viscosity 1 mm²/s.
- All duty points between the individual stage characteristics can be achieved by adapting the impeller diameters.

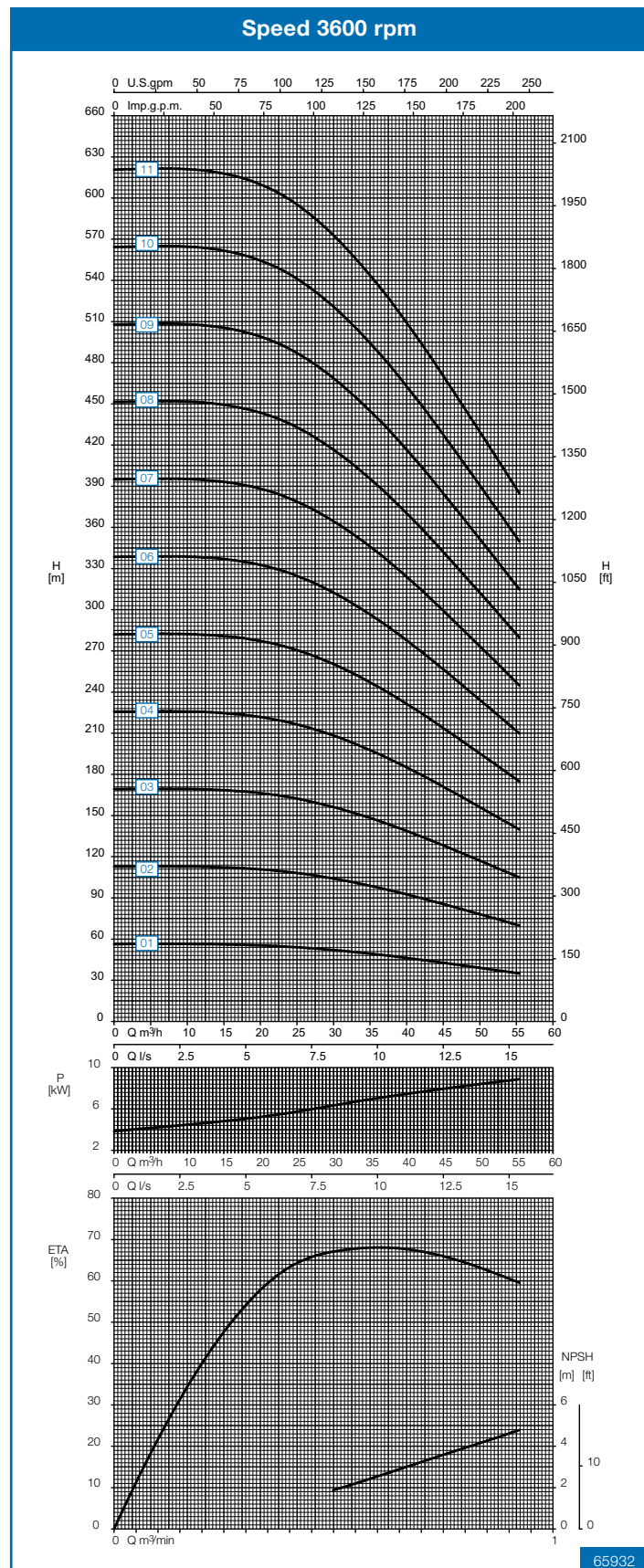
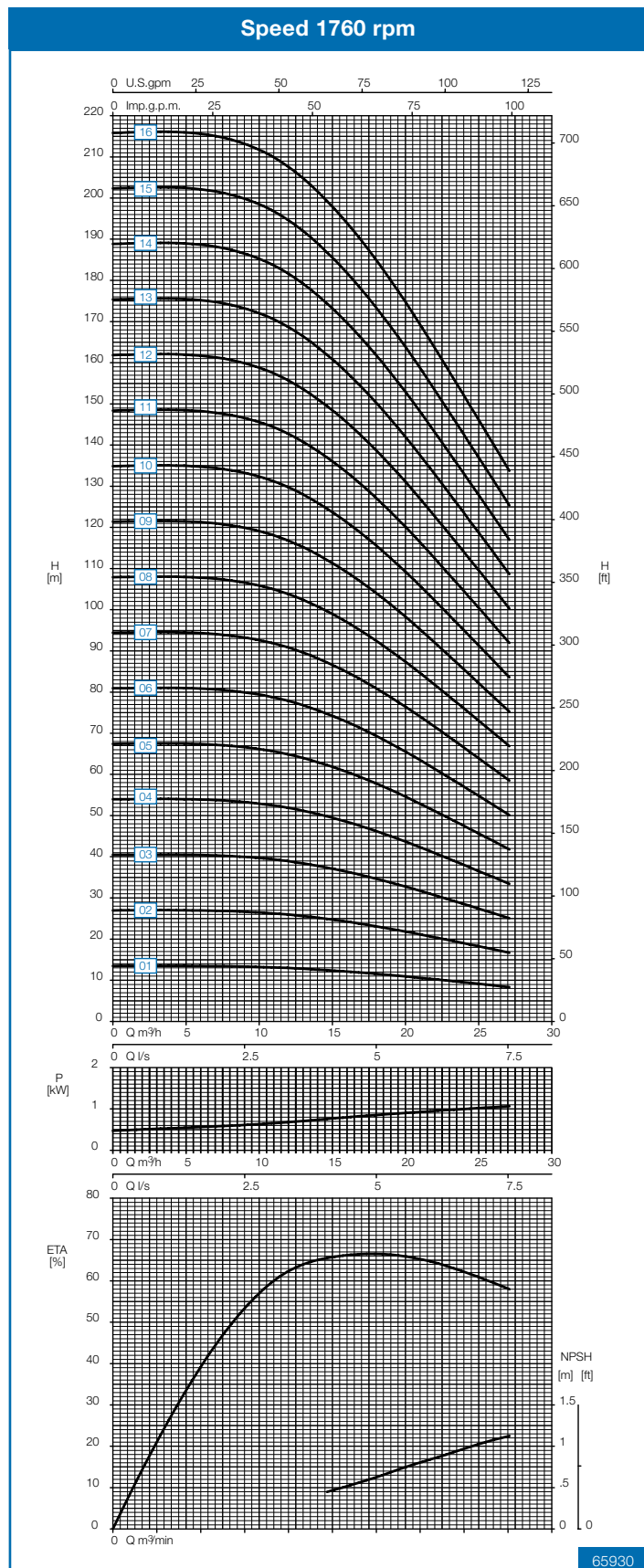

Performance curve

Type 50-195.1

Notes to performance curves

- Curves valid according to DIN EN ISO 9906/2B.
- Power data refers to clean water, density 1 kg/dm³, viscosity 1 mm²/s.
- All duty points between the individual stage characteristics can be achieved by adapting the impeller diameters.

Speed 1760 rpm

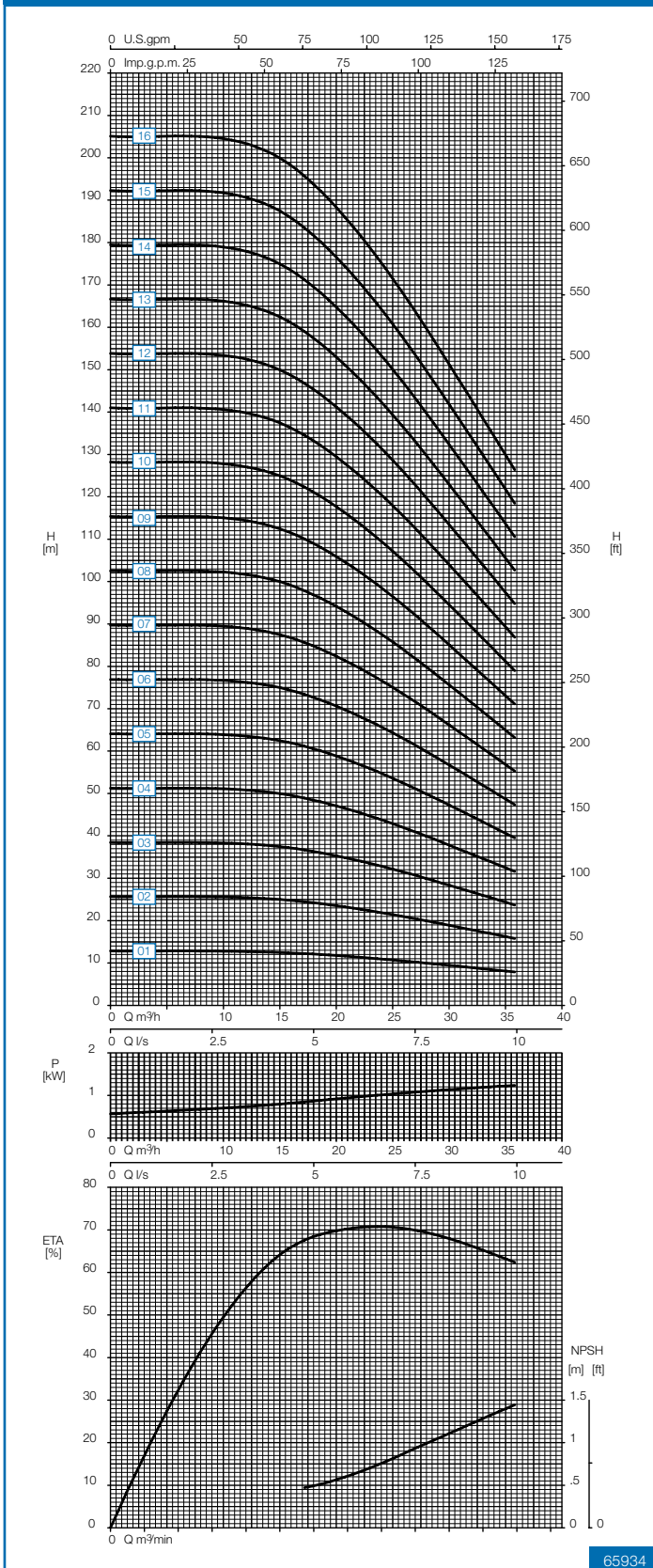

65934

Speed 3600 rpm

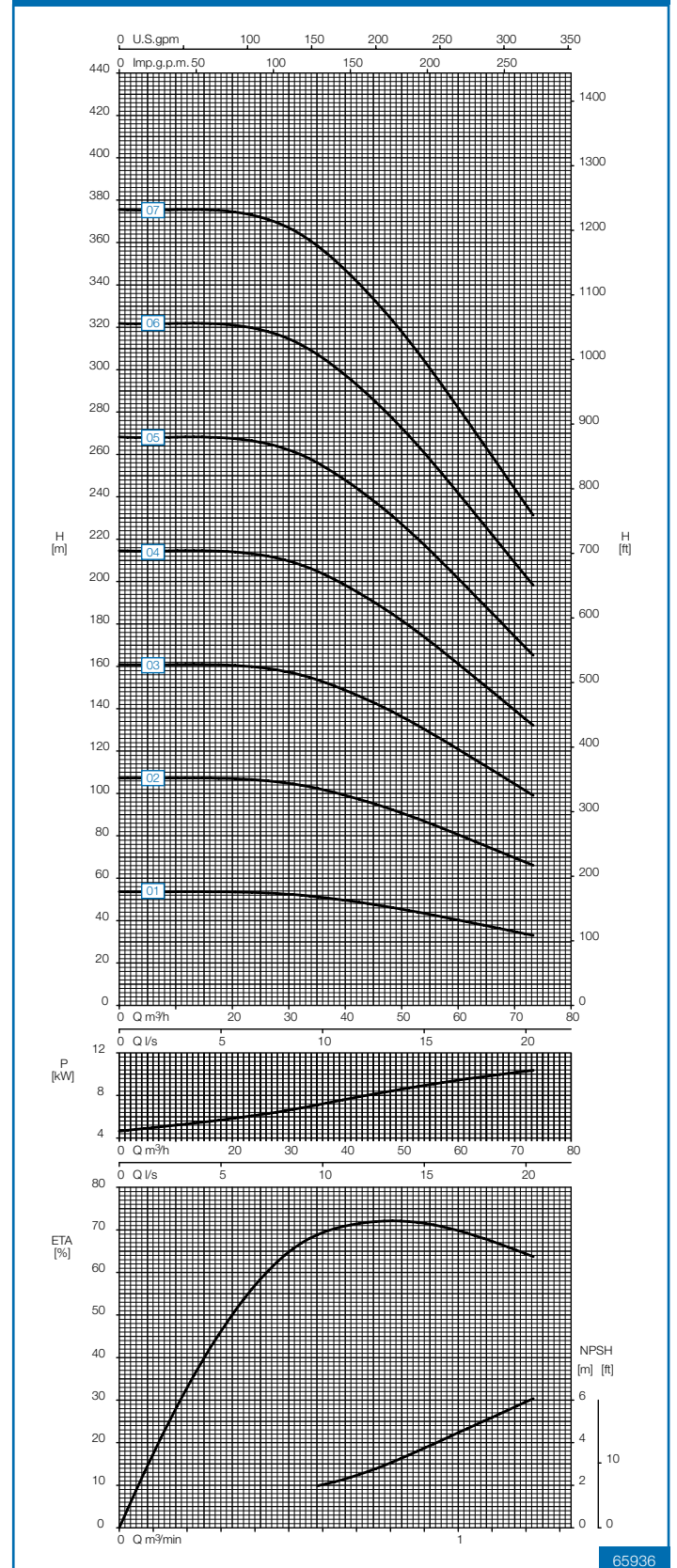

65936

Performance curve

Type 50-195.2

Notes to performance curves

- Curves valid according to DIN EN ISO 9906/2B.
- Power data refers to clean water, density 1 kg/dm³, viscosity 1 mm²/s.
- All duty points between the individual stage characteristics can be achieved by adapting the impeller diameters.

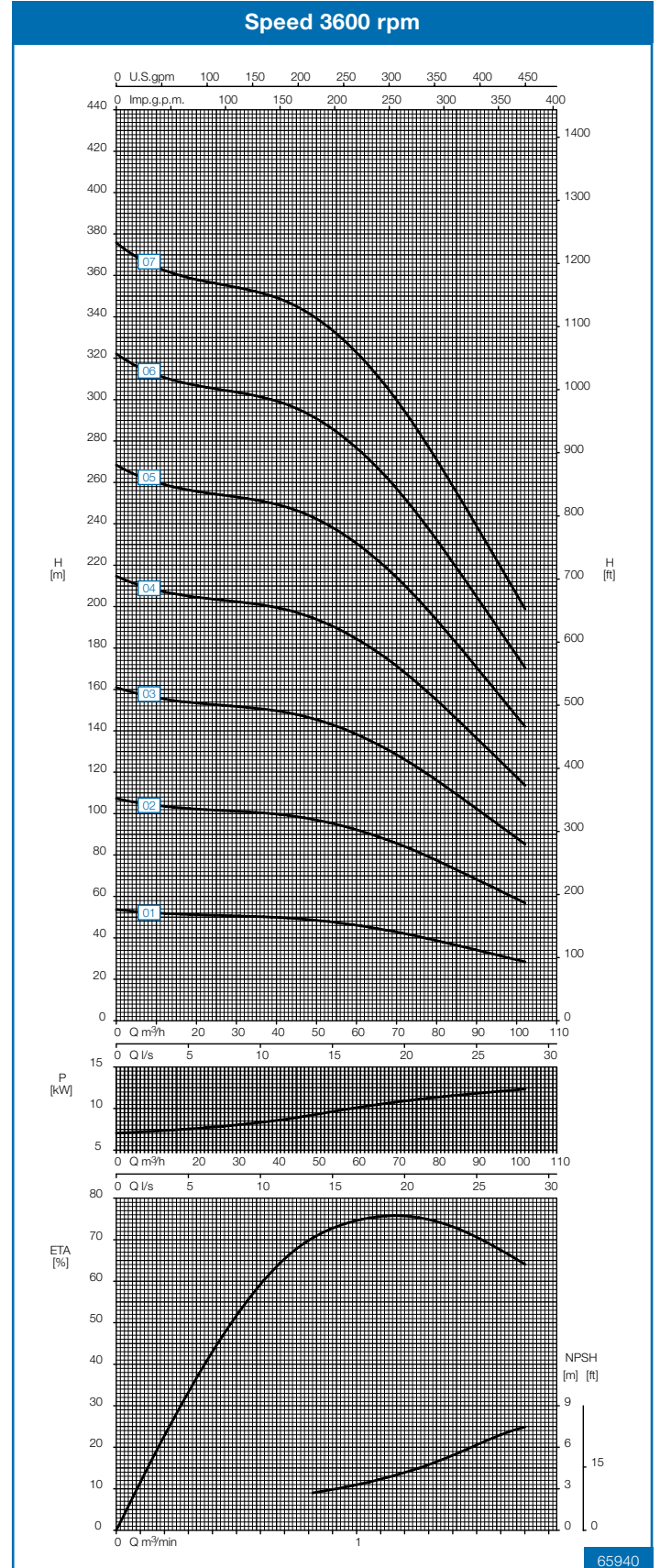
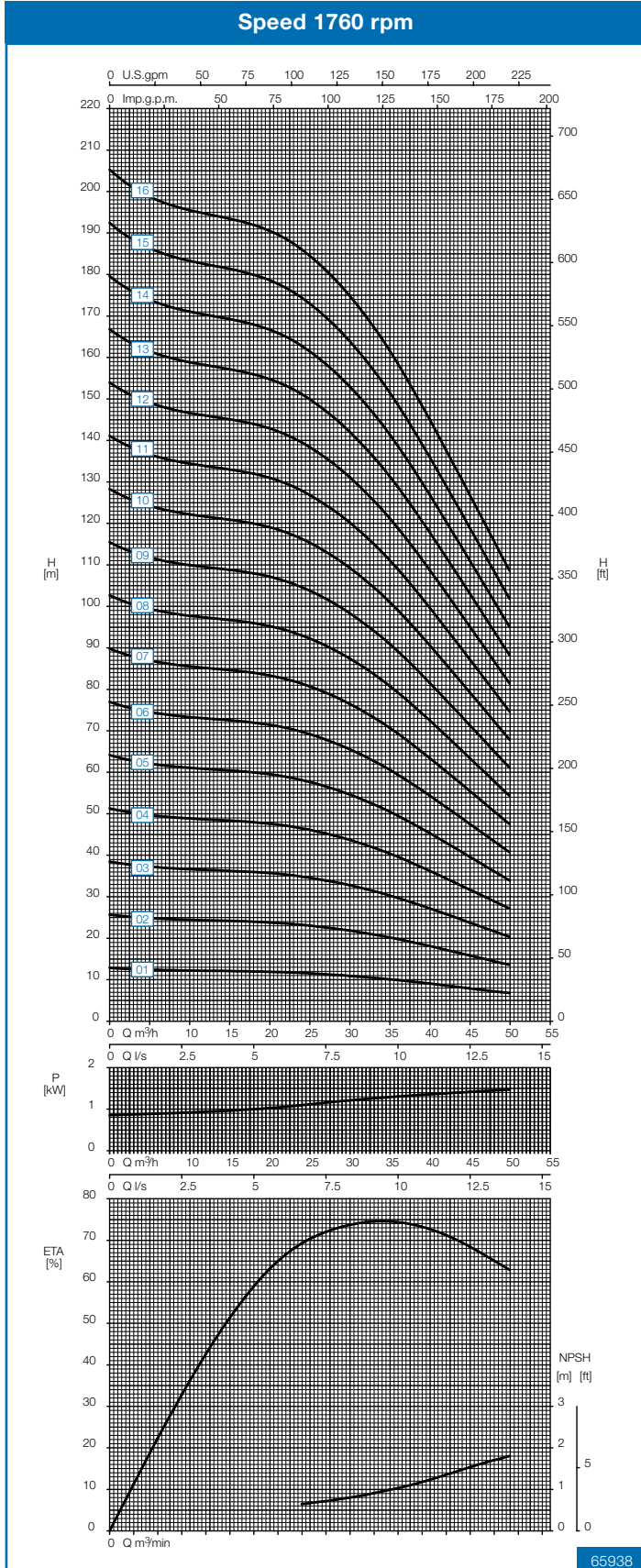

Performance curve

Type 50-195.3

Notes to performance curves

- Curves valid according to DIN EN ISO 9906/2B.
- Power data refers to clean water, density 1 kg/dm³, viscosity 1 mm²/s.
- All duty points between the individual stage characteristics can be achieved by adapting the impeller diameters.

Speed 1760 rpm

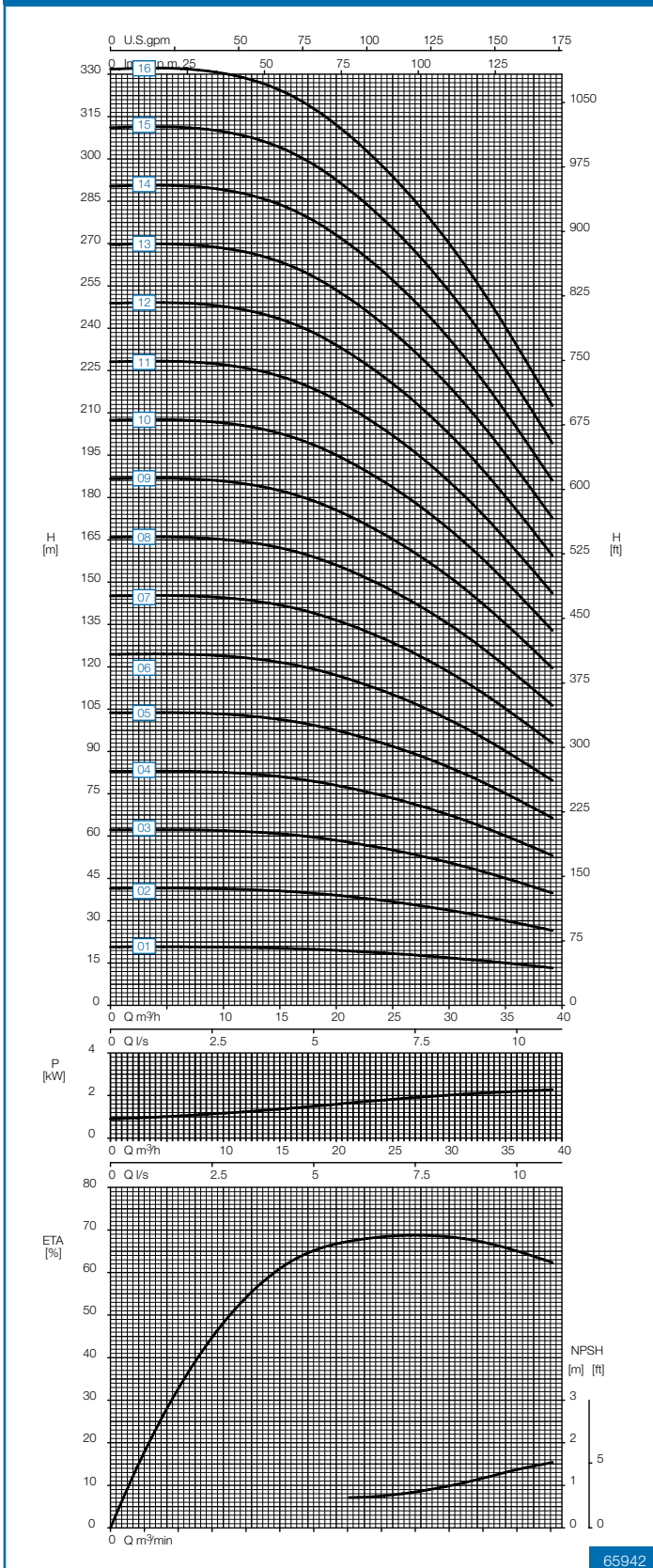

65942

Speed 3600 rpm

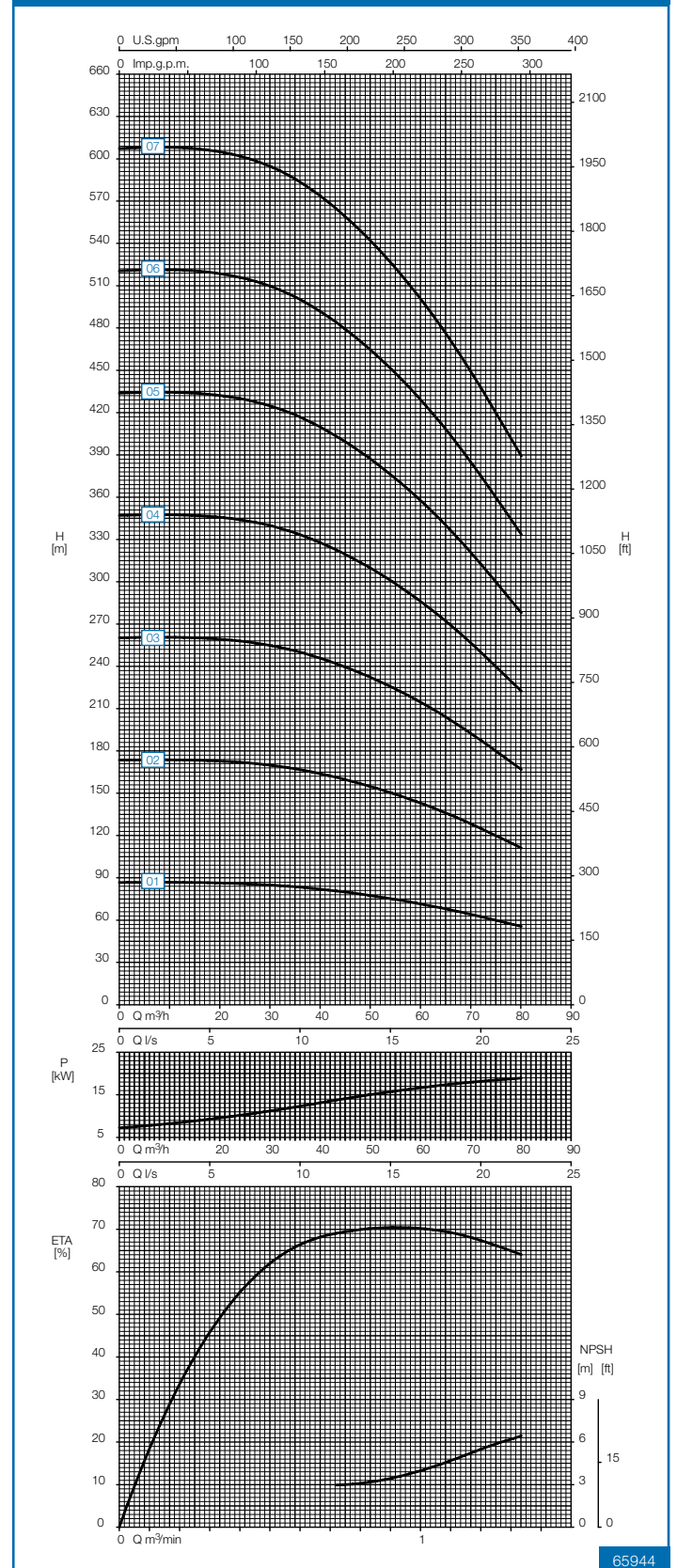

65944

Performance curve

Type 50-195.4

Notes to performance curves

- Curves valid according to DIN EN ISO 9906/2B.
- Power data refers to clean water, density 1 kg/dm³, viscosity 1 mm²/s.
- All duty points between the individual stage characteristics can be achieved by adapting the impeller diameters.

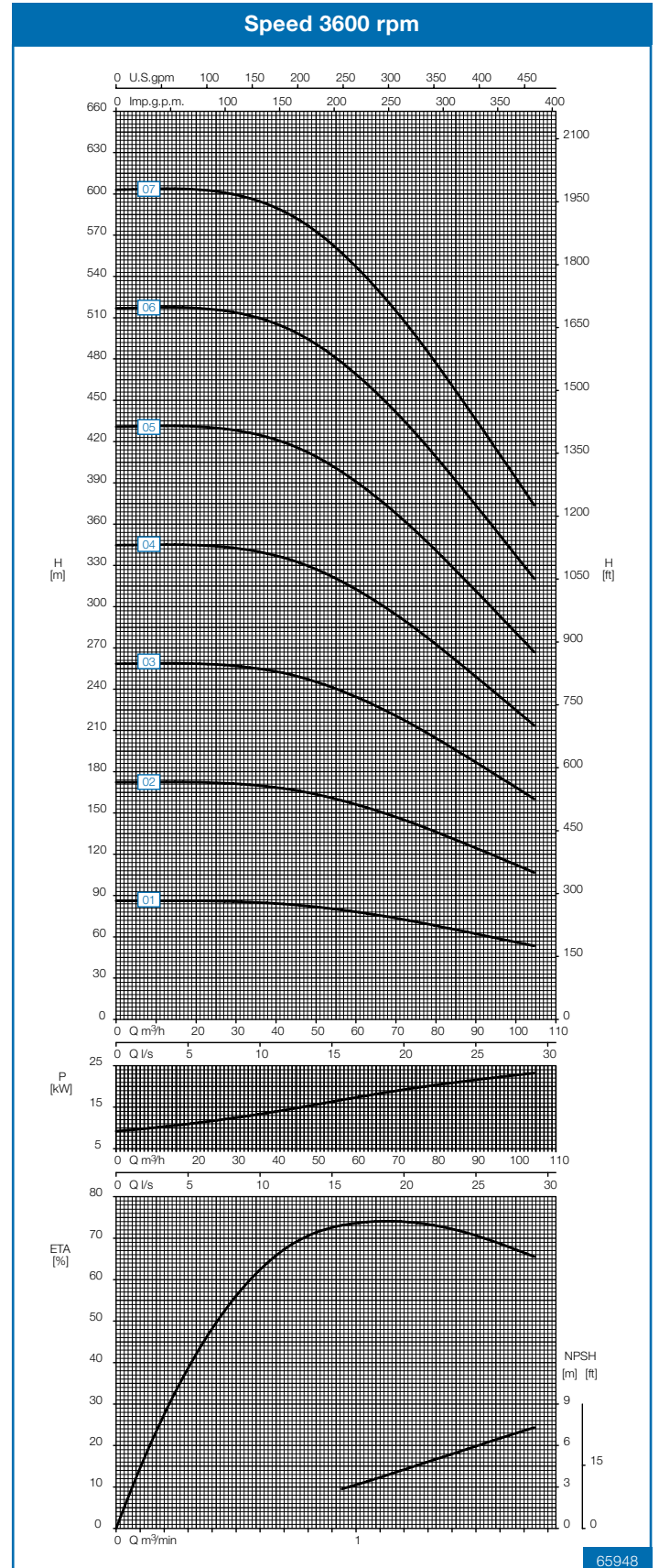
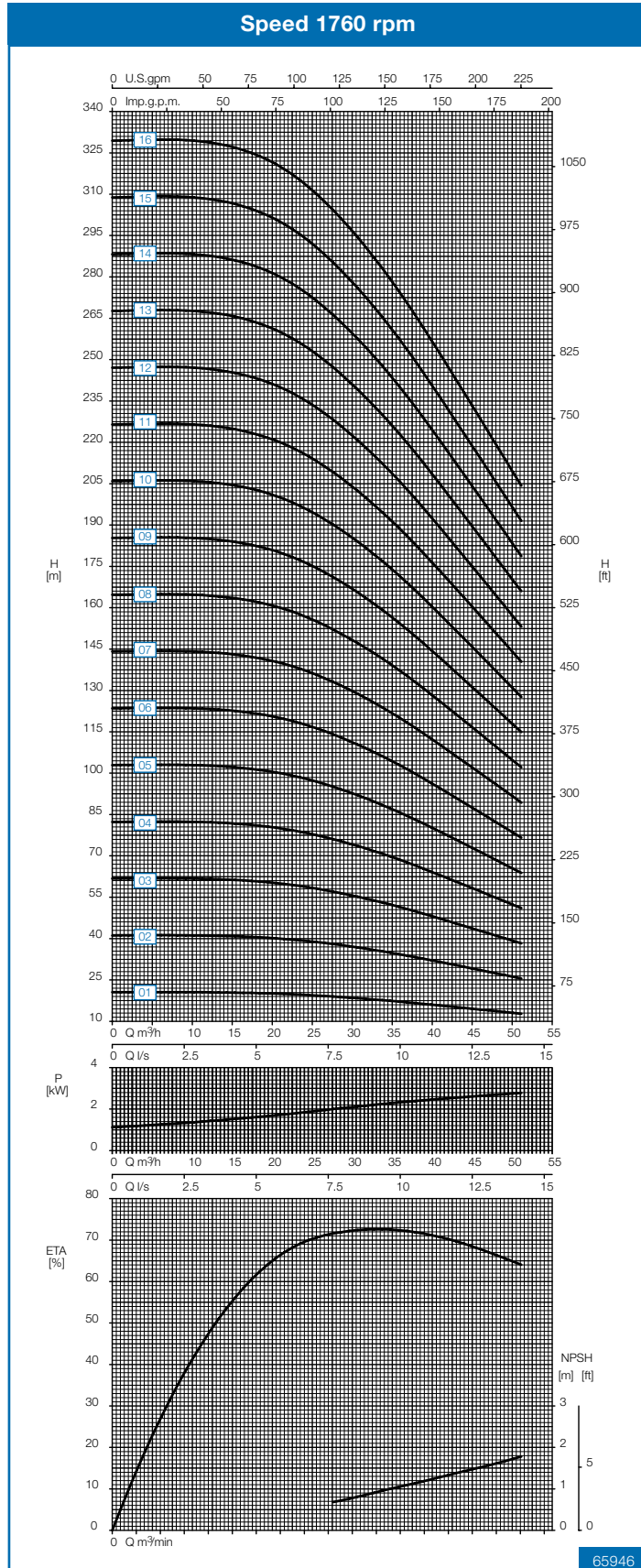

Performance curve

Type 80-220.1

Notes to performance curves

- Curves valid according to DIN EN ISO 9906/2B.
- Power data refers to clean water, density 1 kg/dm³, viscosity 1 mm²/s.
- All duty points between the individual stage characteristics can be achieved by adapting the impeller diameters.

Speed 1760 rpm

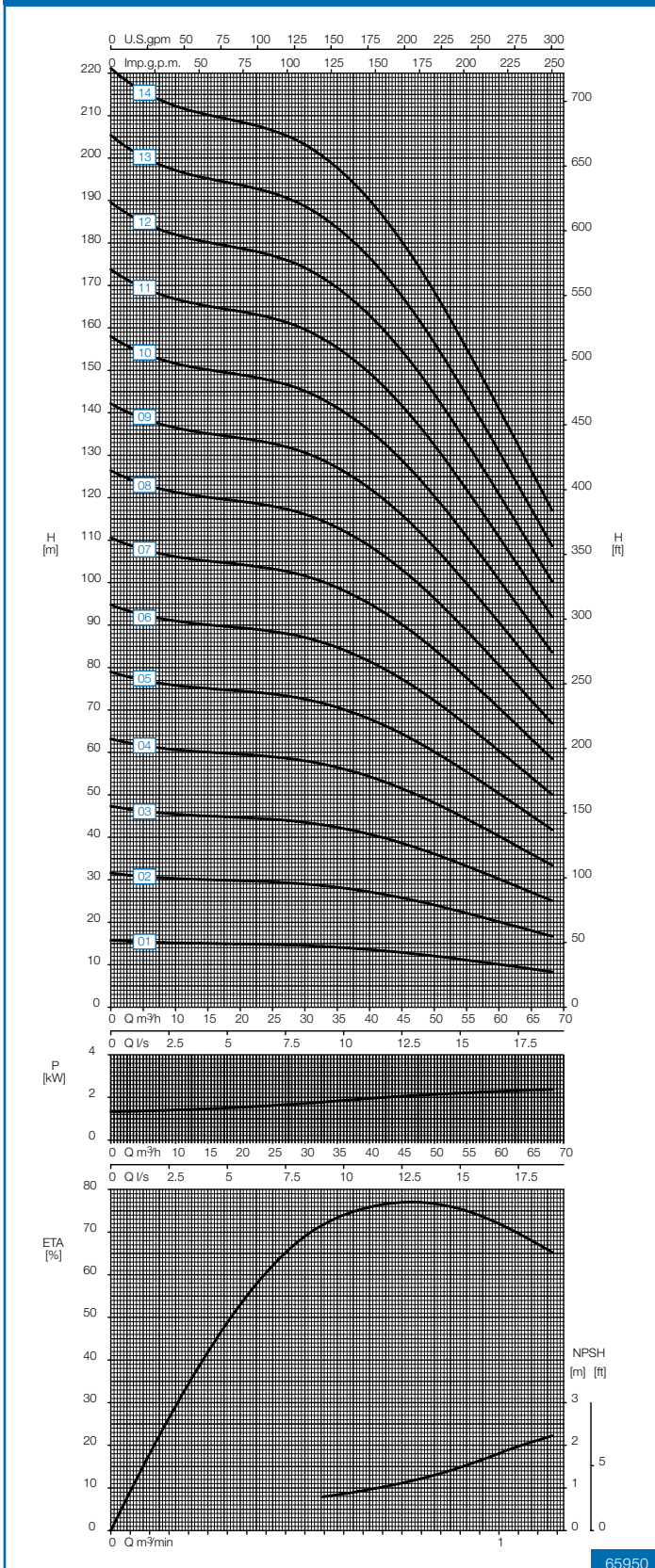

65950

Speed 3600 rpm

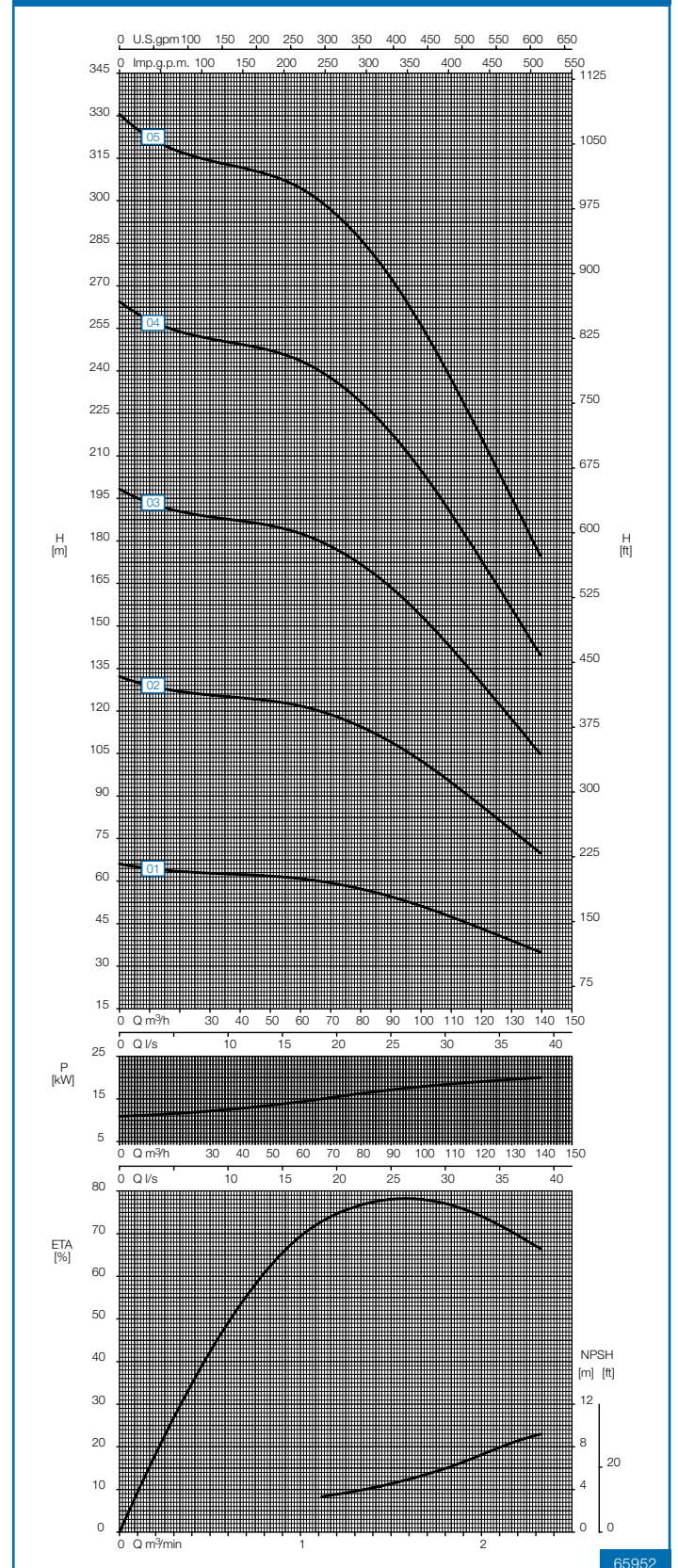

65952

Performance curve

Type 80-220.2

Notes to performance curves

- Curves valid according to DIN EN ISO 9906/2B.
- Power data refers to clean water, density 1 kg/dm³, viscosity 1 mm²/s.
- All duty points between the individual stage characteristics can be achieved by adapting the impeller diameters.

Speed 1760 rpm

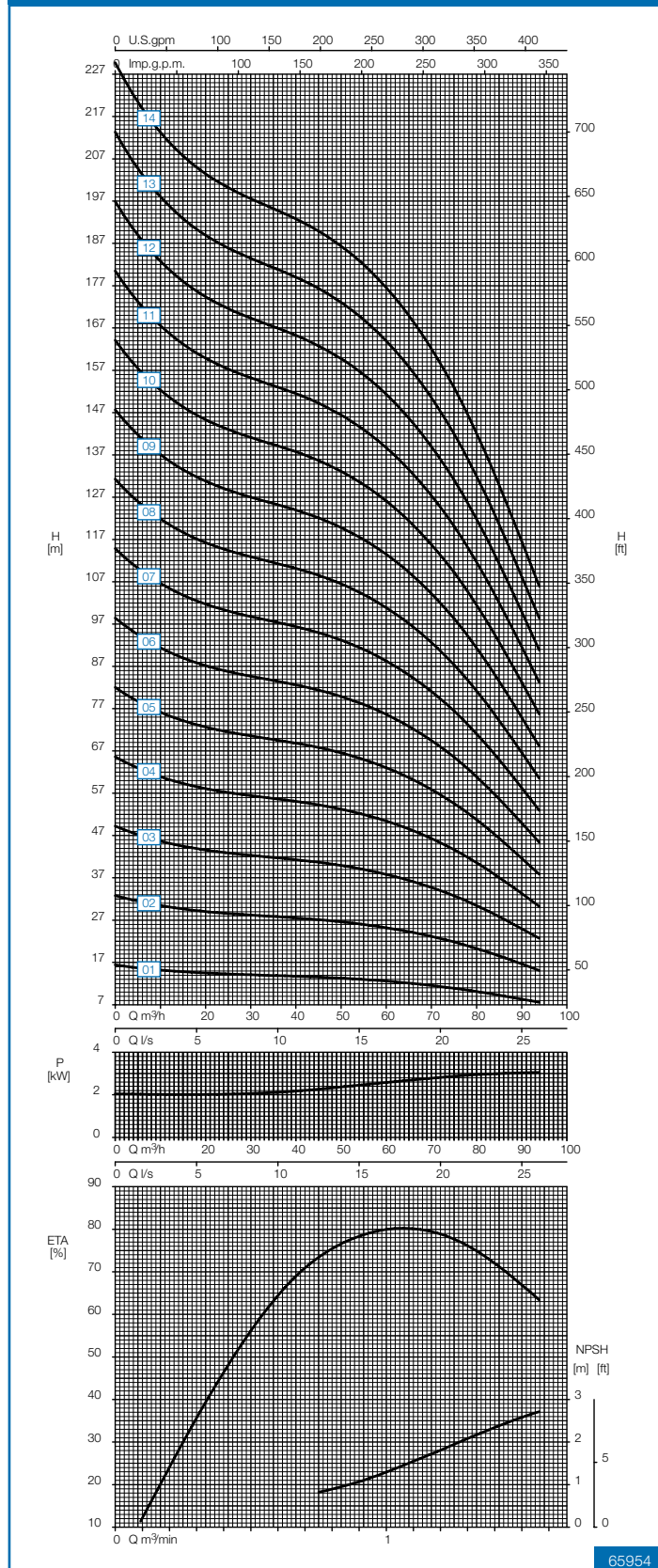

65954

Speed 3600 rpm

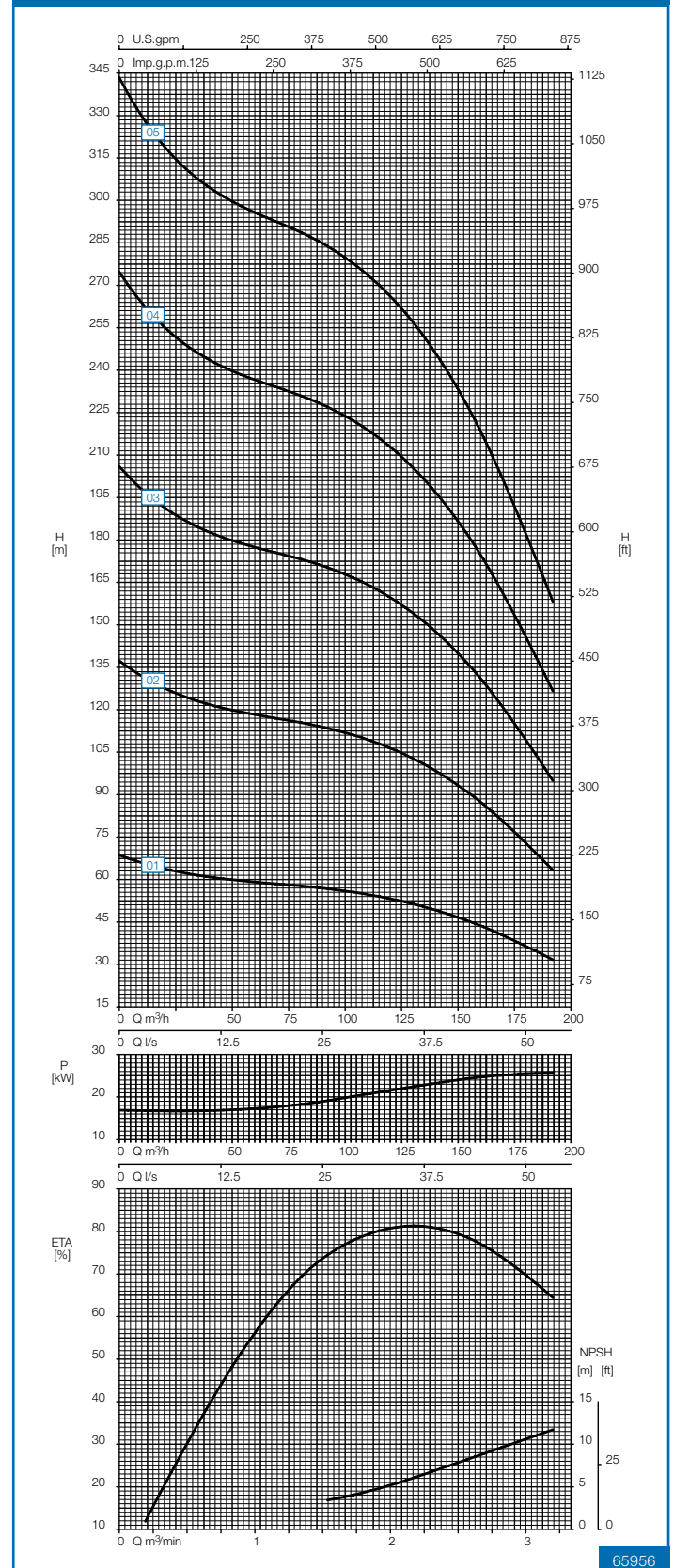

65956

Performance curve

Type 80-220.3

Notes to performance curves

- Curves valid according to DIN EN ISO 9906/2B.
- Power data refers to clean water, density 1 kg/dm³, viscosity 1 mm²/s.
- All duty points between the individual stage characteristics can be achieved by adapting the impeller diameters.

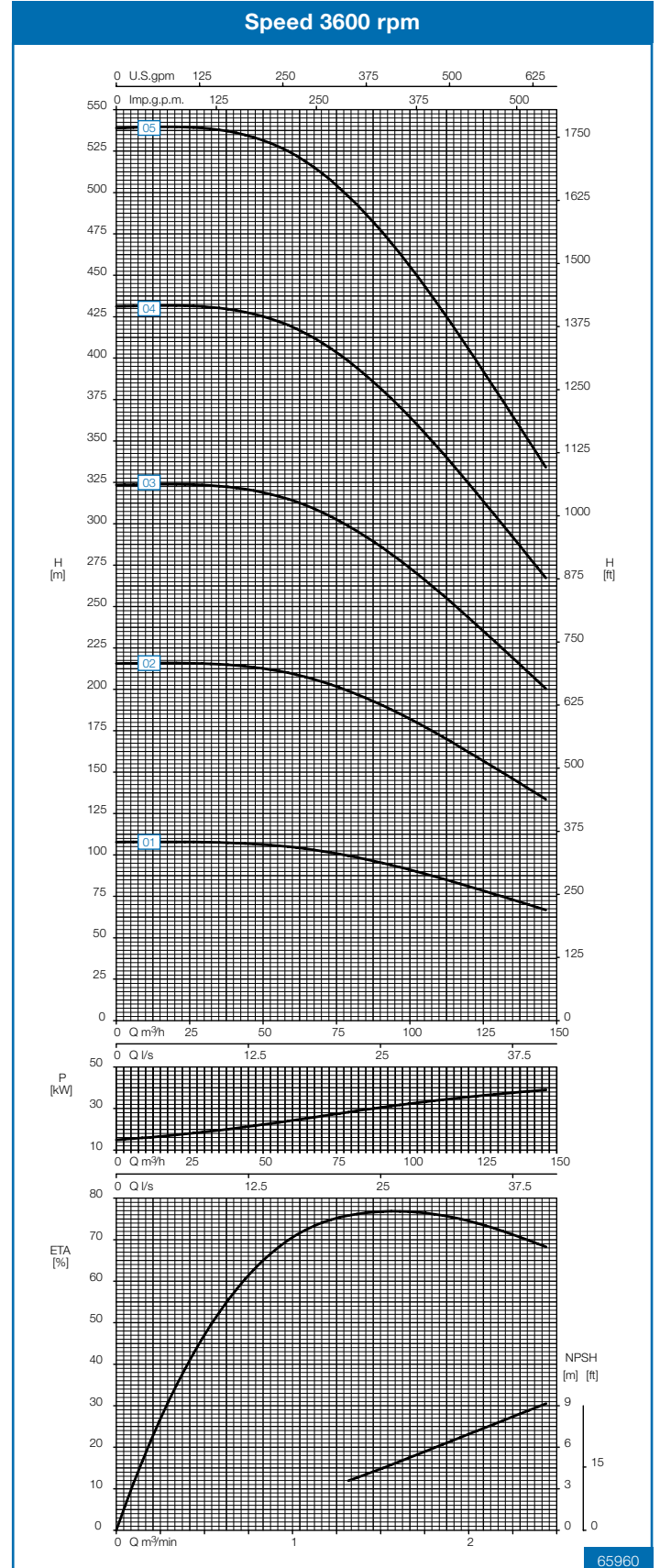
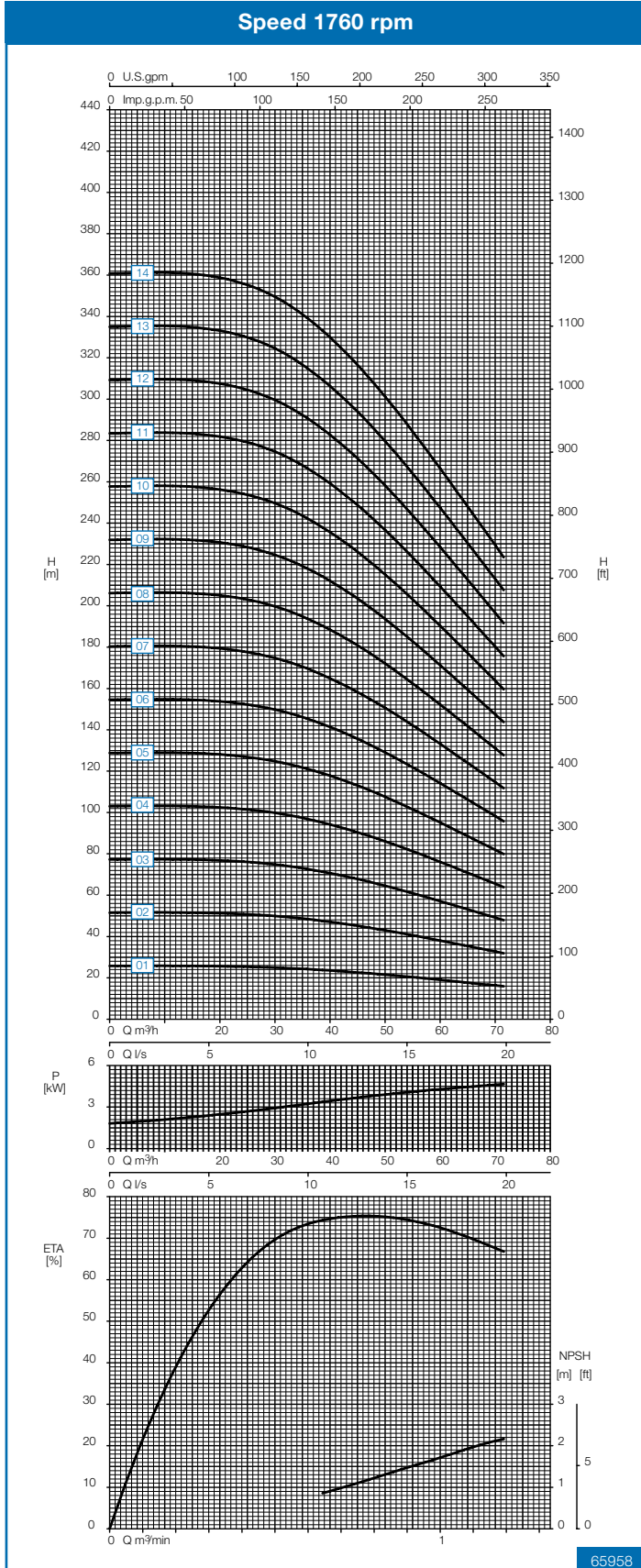

Performance curve

Type 80-220.4

Notes to performance curves

- Curves valid according to DIN EN ISO 9906/2B.
- Power data refers to clean water, density 1 kg/dm³, viscosity 1 mm²/s.
- All duty points between the individual stage characteristics can be achieved by adapting the impeller diameters.

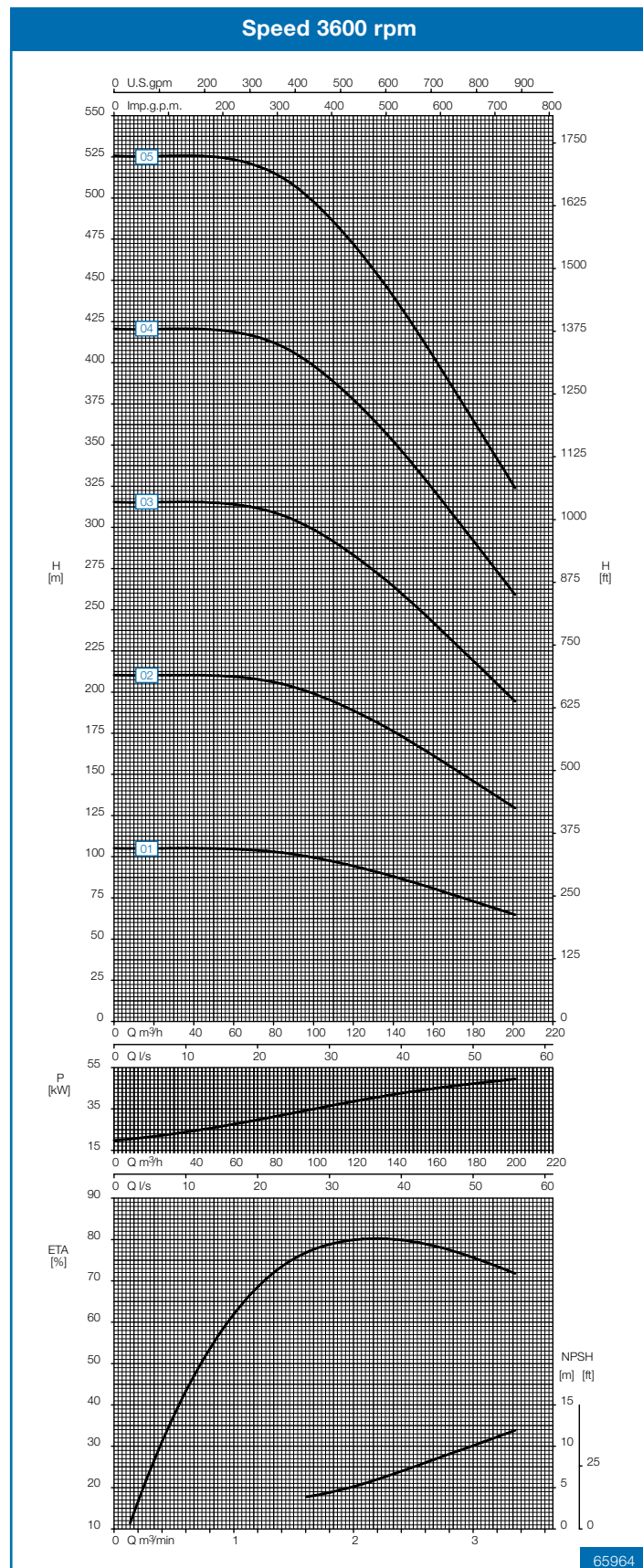
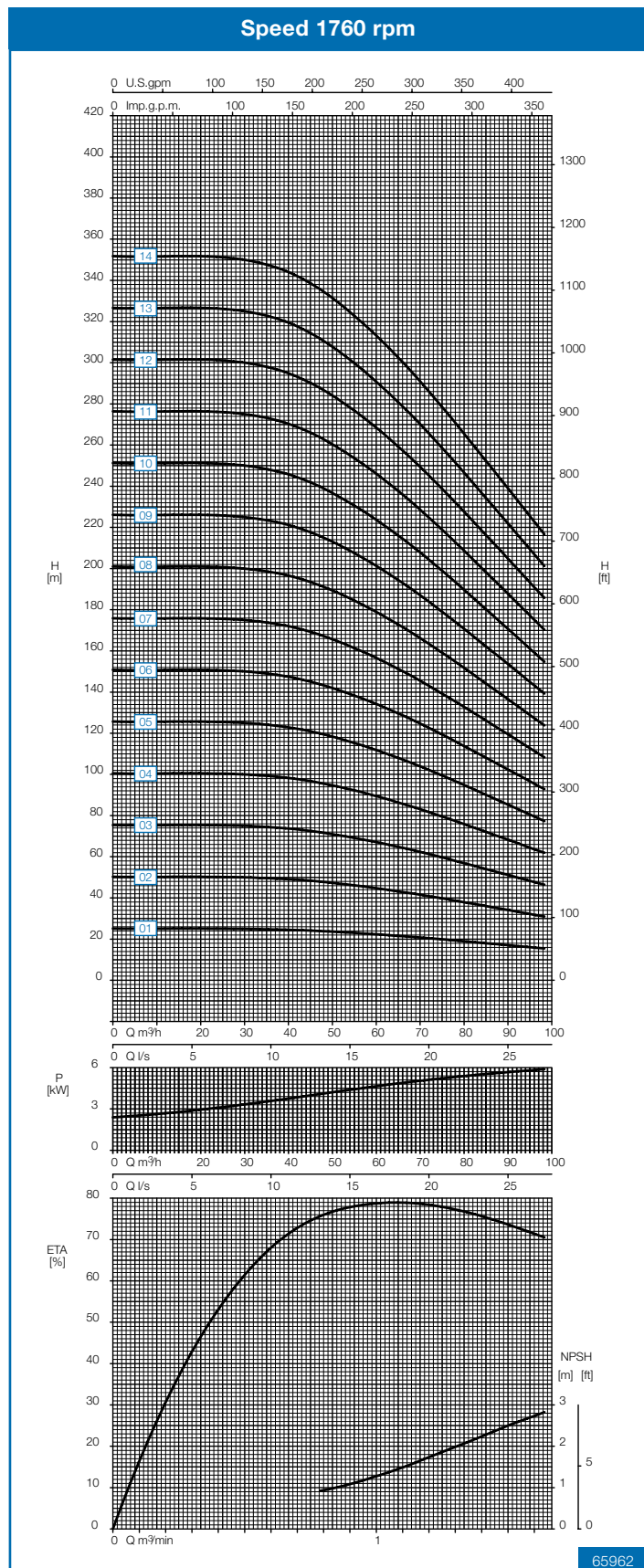

Performance curve

Type 100-240.1

Notes to performance curves

- Curves valid according to DIN EN ISO 9906/2B.
- Power data refers to clean water, density 1 kg/dm³, viscosity 1 mm²/s.
- All duty points between the individual stage characteristics can be achieved by adapting the impeller diameters.

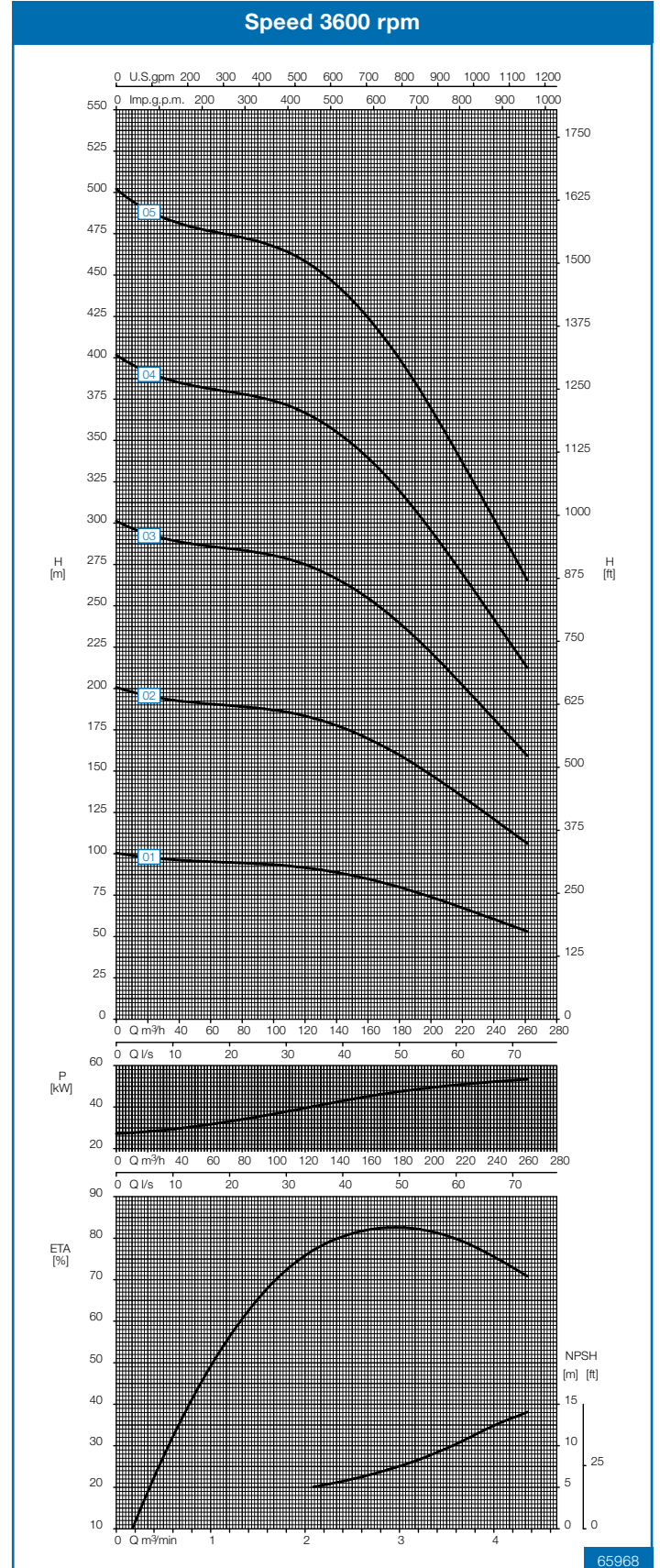
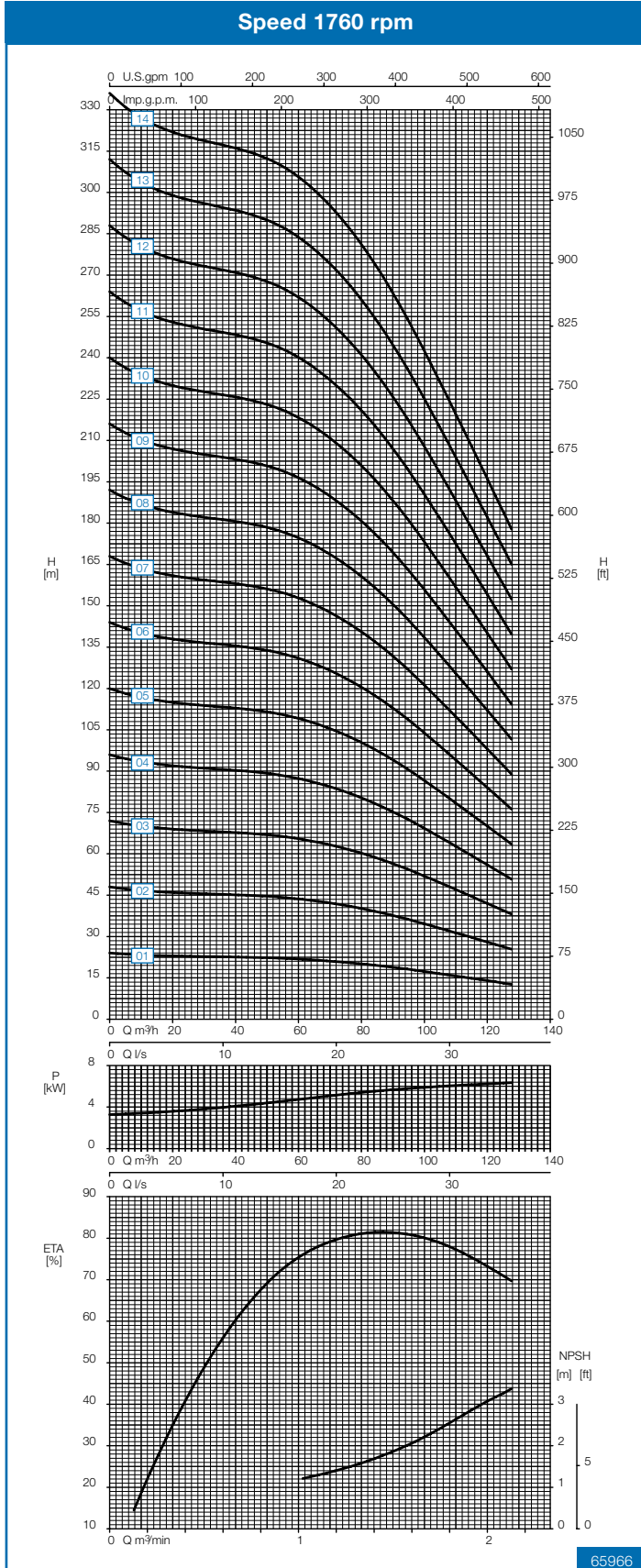

Performance curve

Type 100-240.2

Notes to performance curves

- Curves valid according to DIN EN ISO 9906/2B.
- Power data refers to clean water, density 1 kg/dm³, viscosity 1 mm²/s.
- All duty points between the individual stage characteristics can be achieved by adapting the impeller diameters.

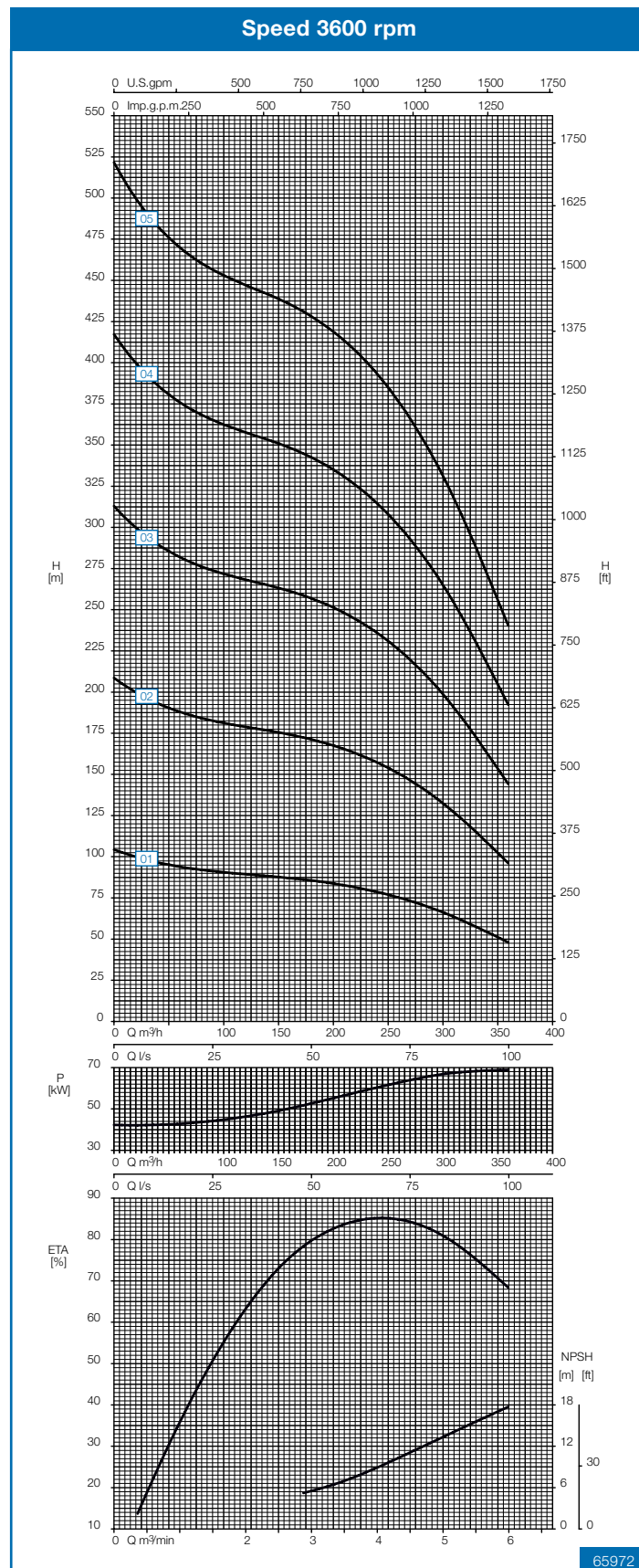
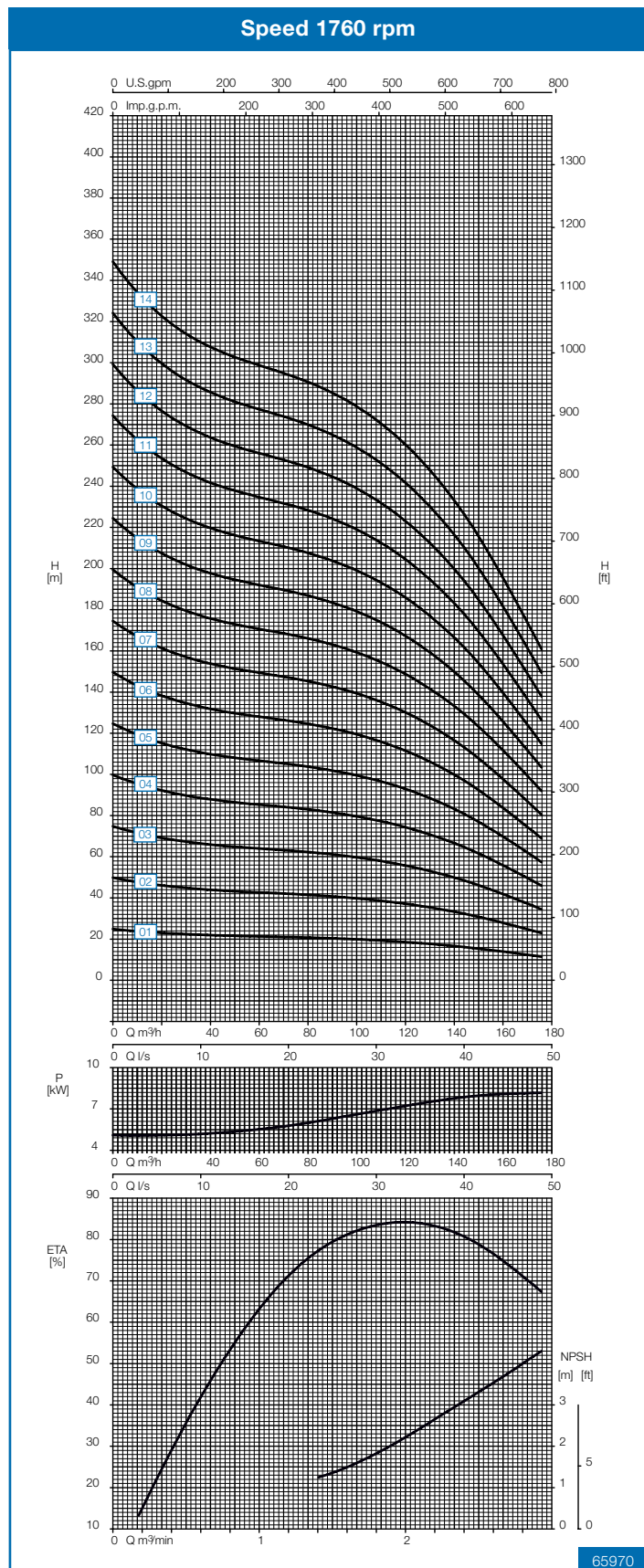

Performance curve

Type 100-240.3

Notes to performance curves

- Curves valid according to DIN EN ISO 9906/2B.
- Power data refers to clean water, density 1 kg/dm³, viscosity 1 mm²/s.
- All duty points between the individual stage characteristics can be achieved by adapting the impeller diameters.

Speed 1760 rpm

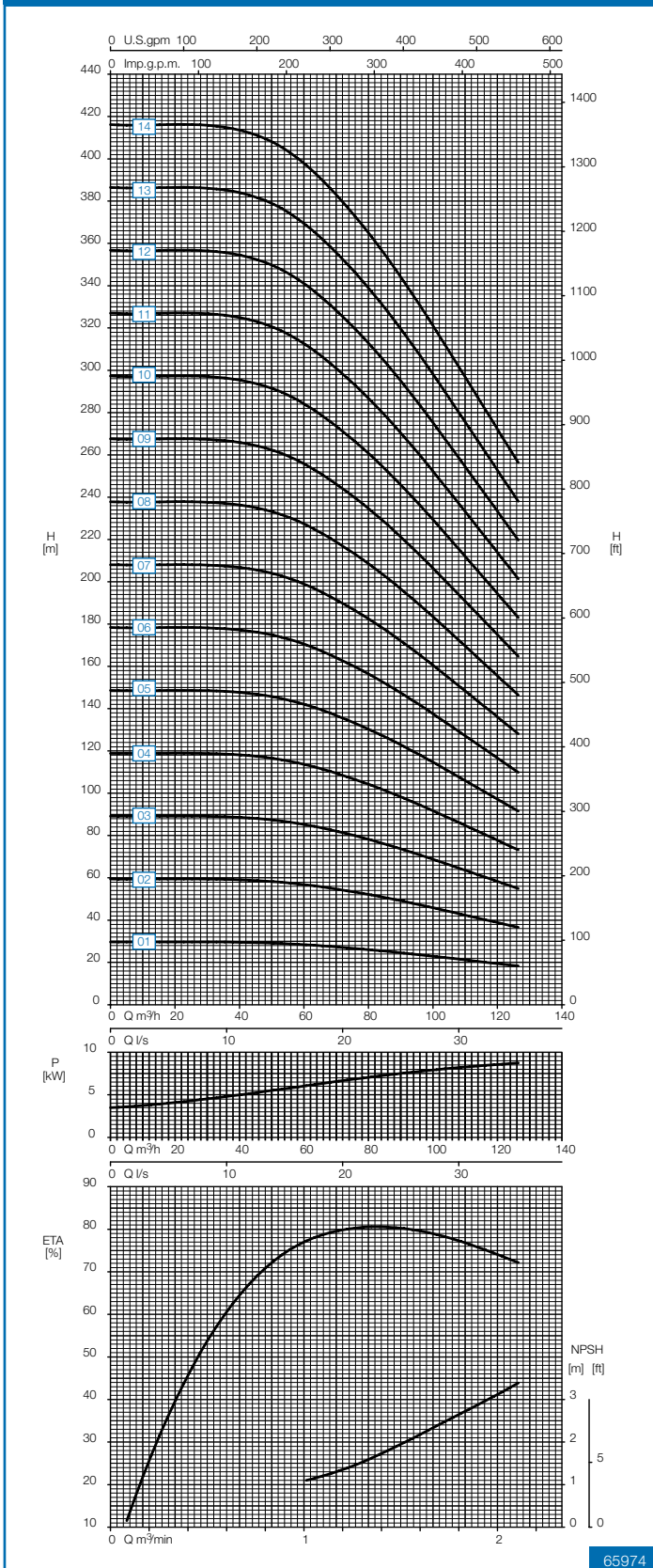

65974

Speed 3600 rpm

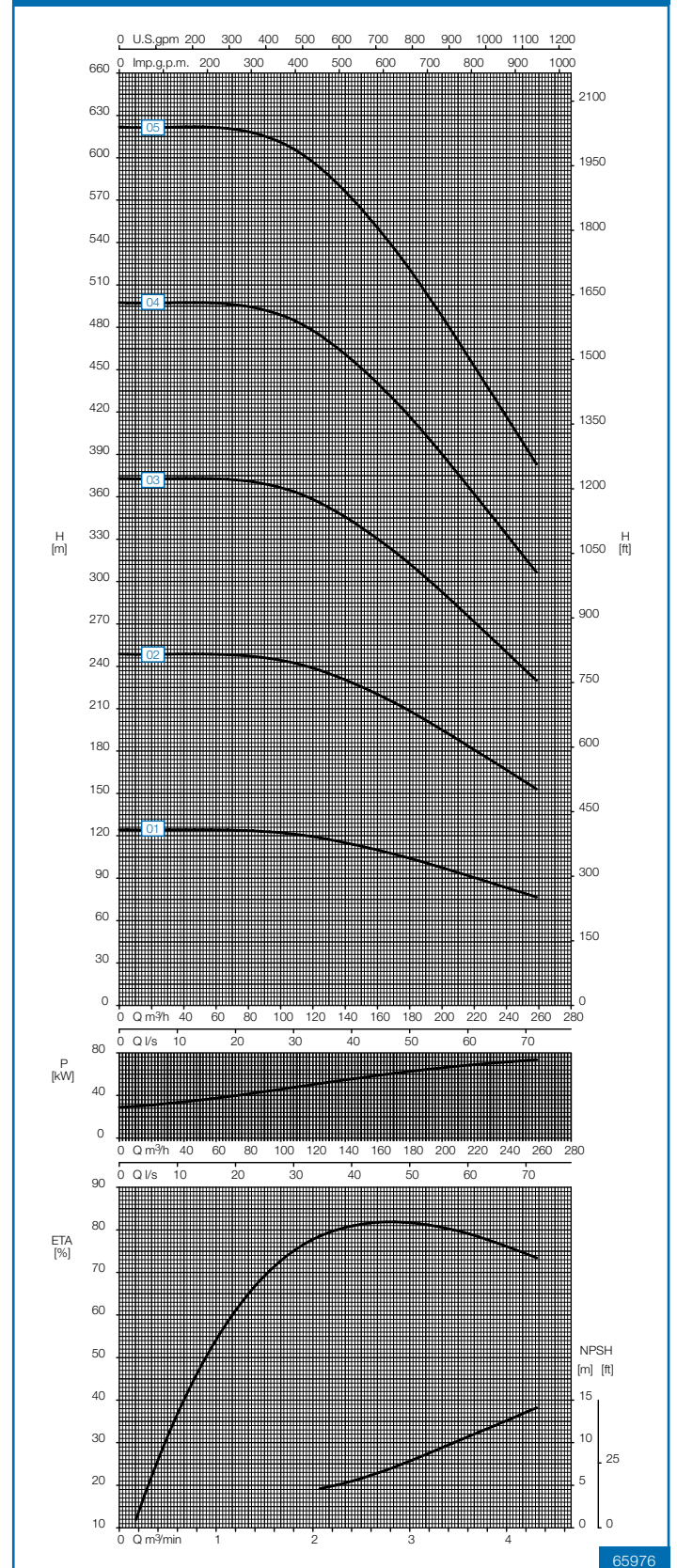

65976

Performance curve

Type 100-240.4

Notes to performance curves

- Curves valid according to DIN EN ISO 9906/2B.
- Power data refers to clean water, density 1 kg/dm³, viscosity 1 mm²/s.
- All duty points between the individual stage characteristics can be achieved by adapting the impeller diameters.

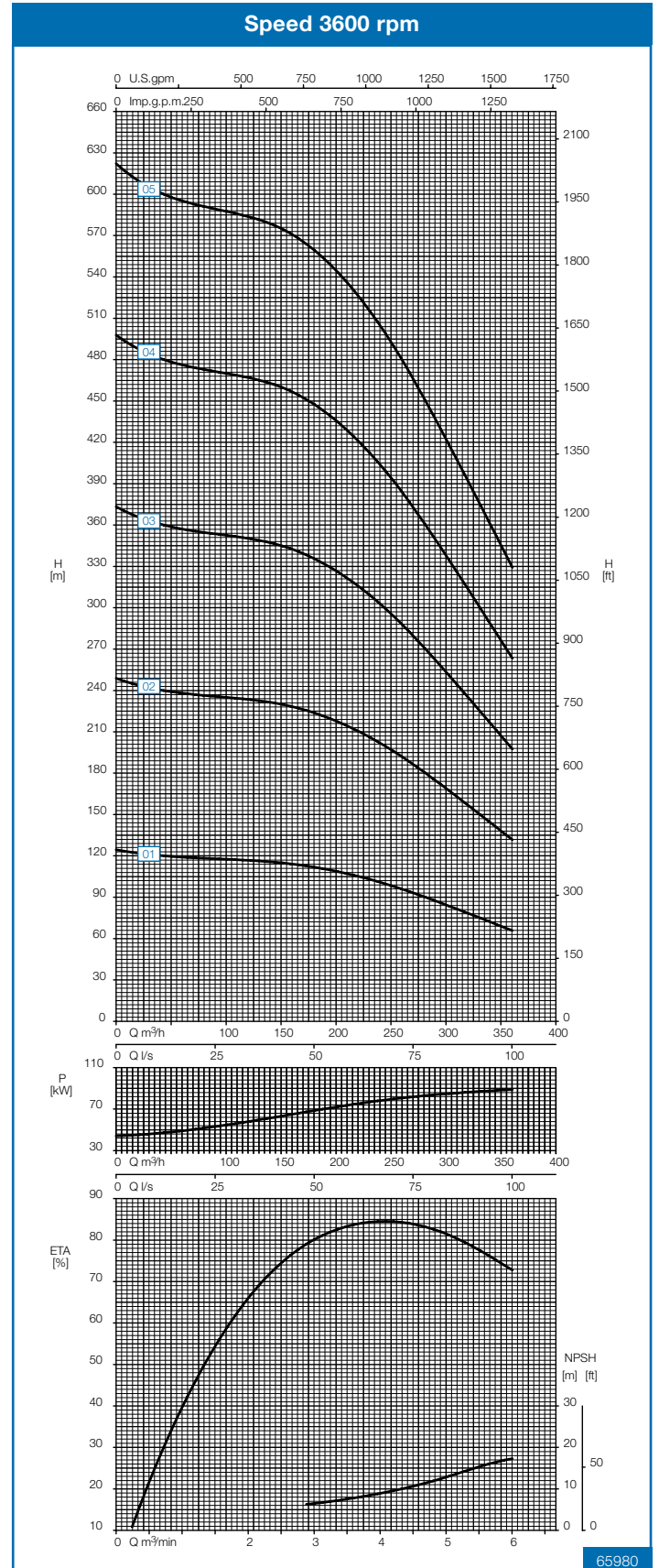
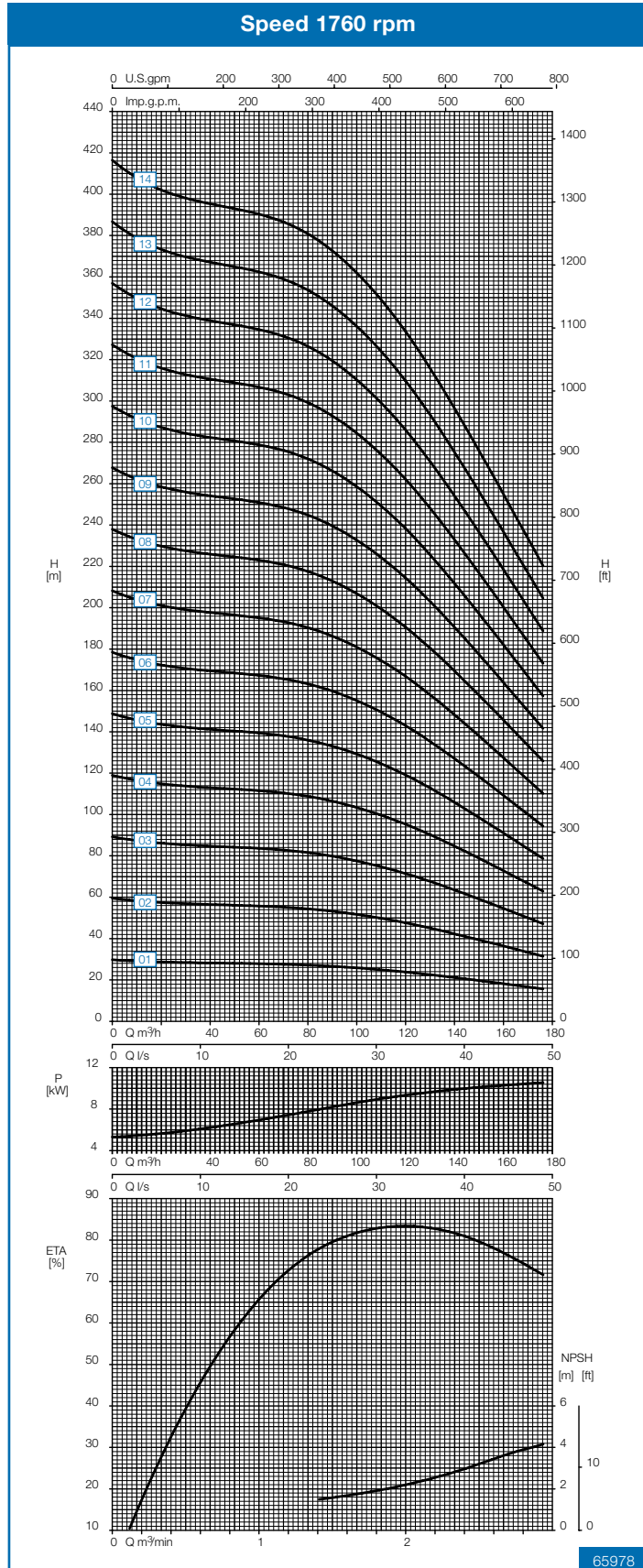

Performance curve

Type 125-260.1

Notes to performance curves

- Curves valid according to DIN EN ISO 9906/2B.
- Power data refers to clean water, density 1 kg/dm³, viscosity 1 mm²/s.
- All duty points between the individual stage characteristics can be achieved by adapting the impeller diameters.

Speed 1760 rpm

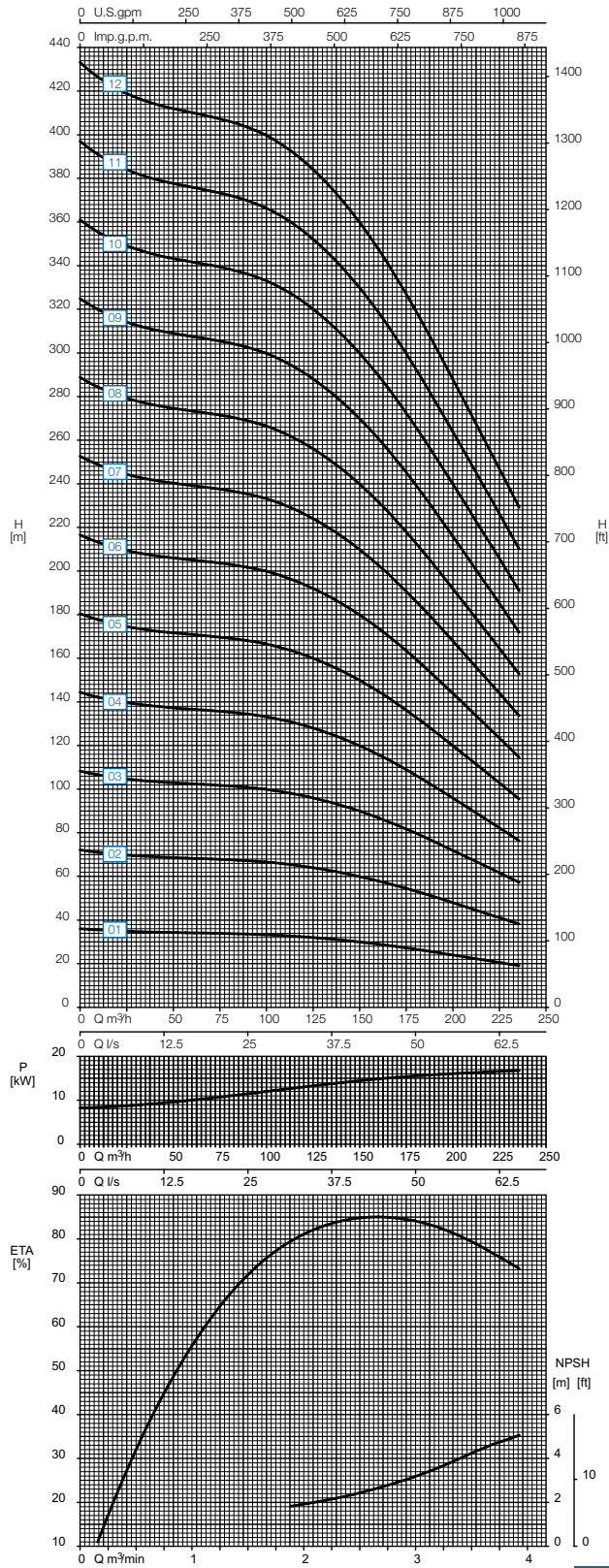

65982

Speed 3600 rpm

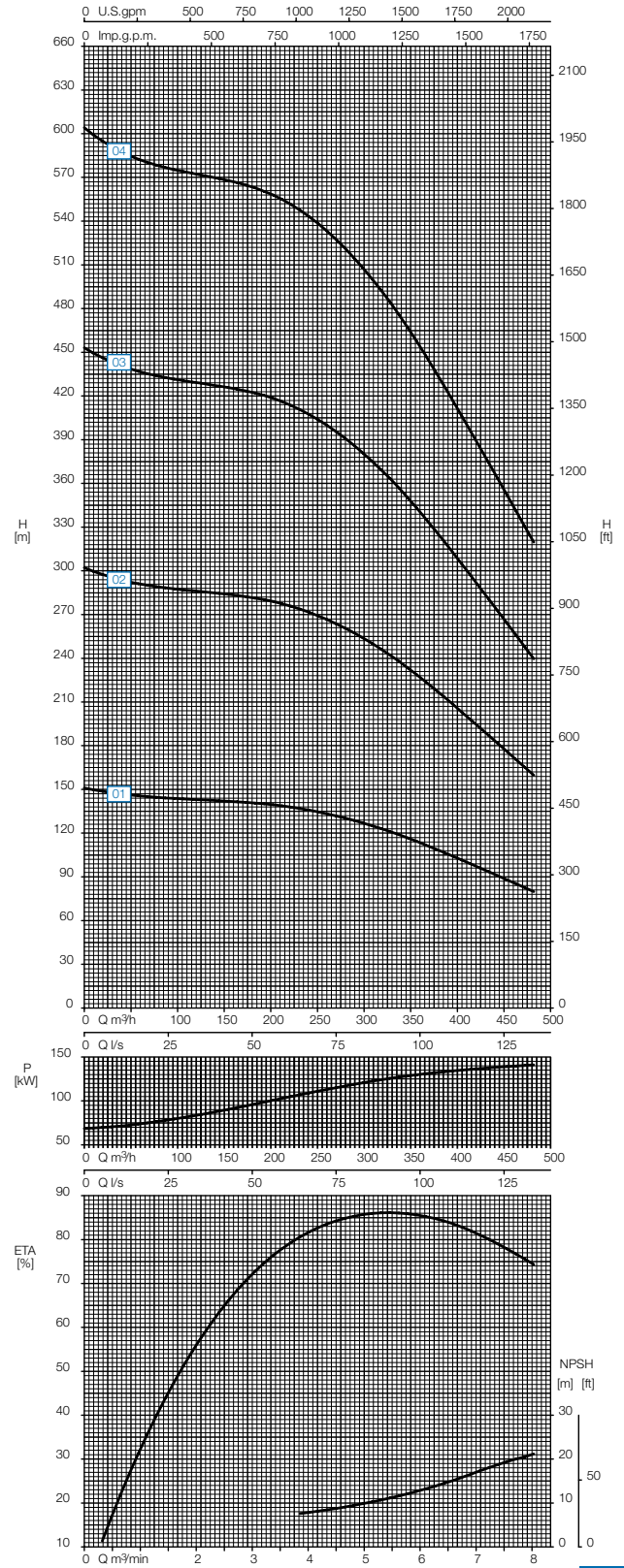

65984

Performance curve

Type 125-260.2

Notes to performance curves

- Curves valid according to DIN EN ISO 9906/2B.
- Power data refers to clean water, density 1 kg/dm³, viscosity 1 mm²/s.
- All duty points between the individual stage characteristics can be achieved by adapting the impeller diameters.

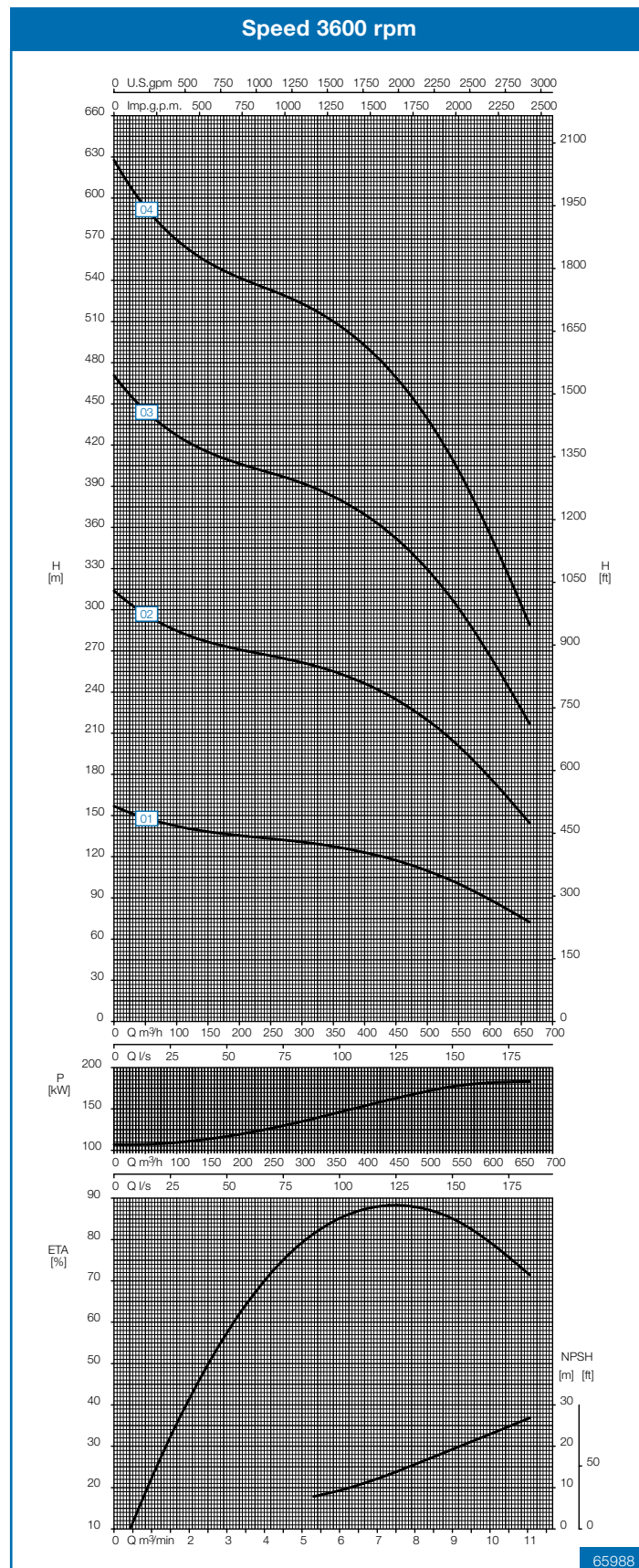
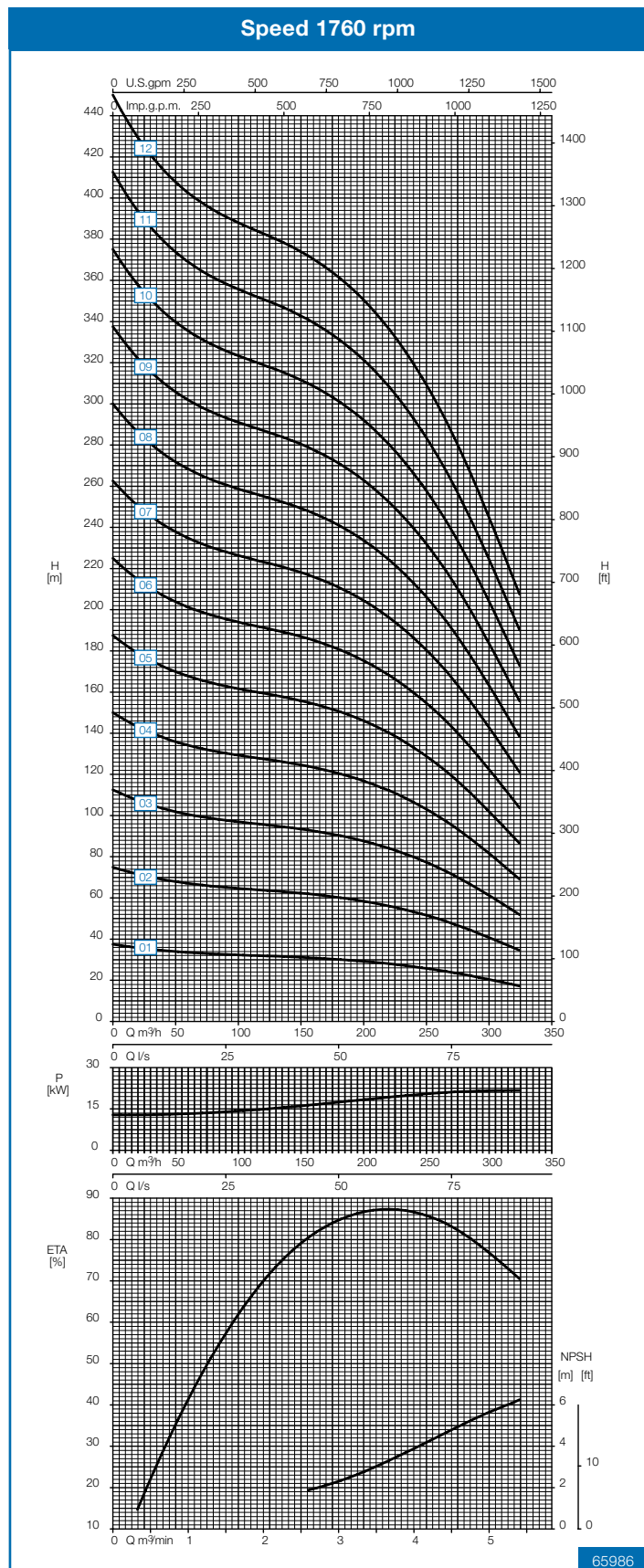

Performance curve

Type 150-305.1

Notes to performance curves

- Curves valid according to DIN EN ISO 9906/2B.
- Power data refers to clean water, density 1 kg/dm³, viscosity 1 mm²/s.
- All duty points between the individual stage characteristics can be achieved by adapting the impeller diameters.

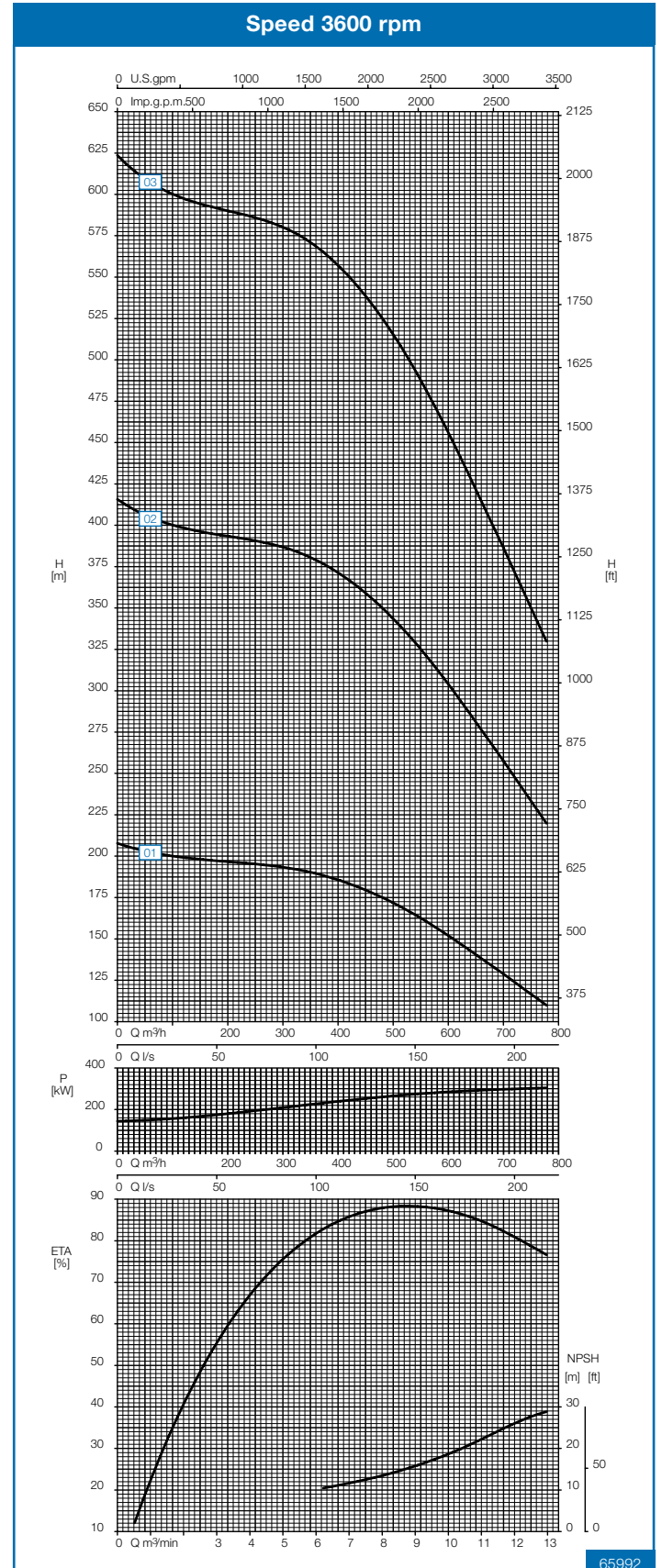
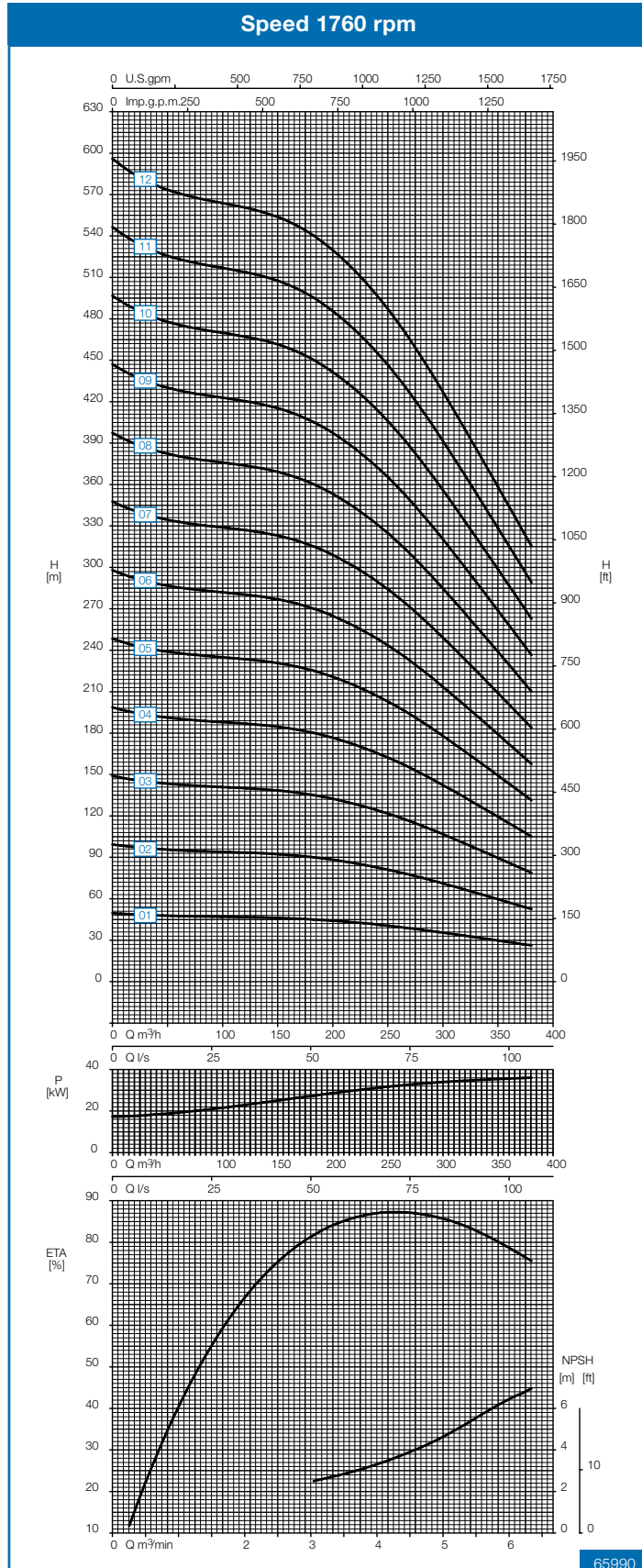

Performance curve

Type 150-305.2

Notes to performance curves

- Curves valid according to DIN EN ISO 9906/2B.
- Power data refers to clean water, density 1 kg/dm³, viscosity 1 mm²/s.
- All duty points between the individual stage characteristics can be achieved by adapting the impeller diameters.

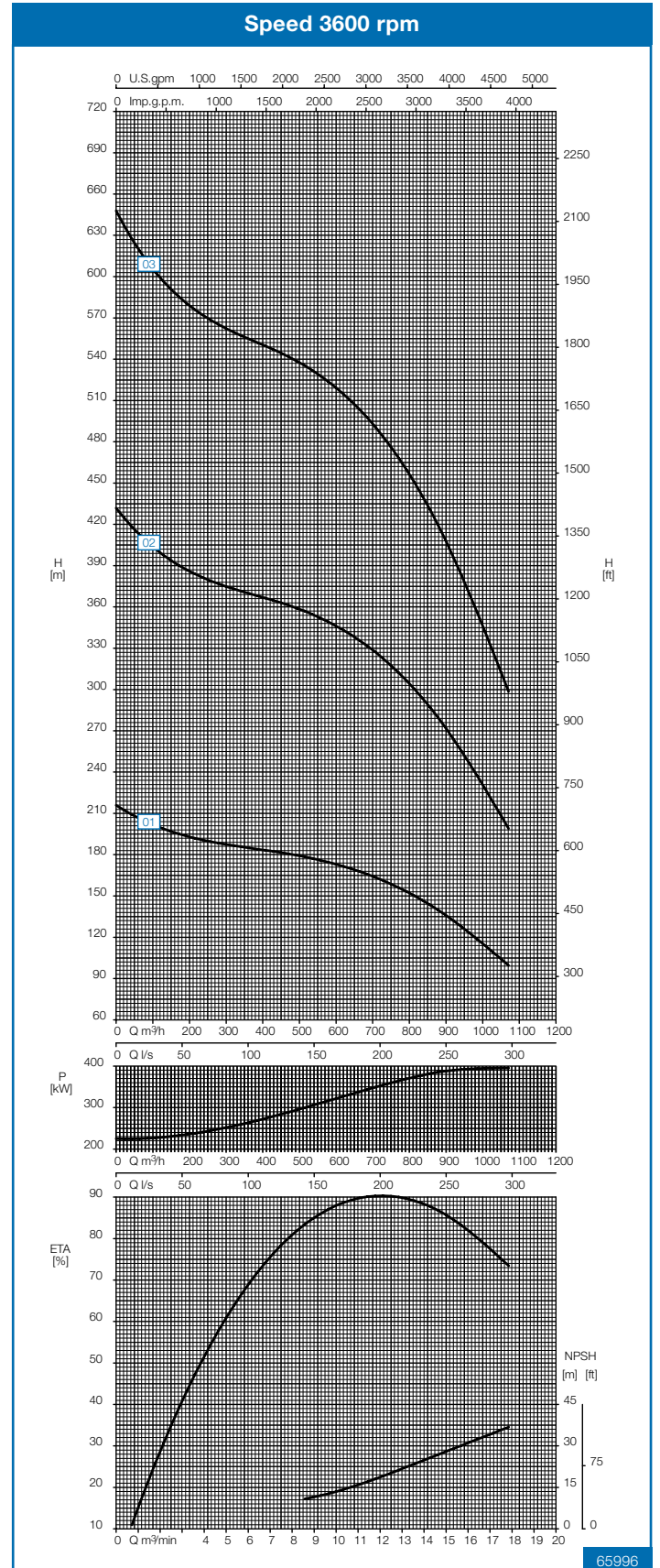
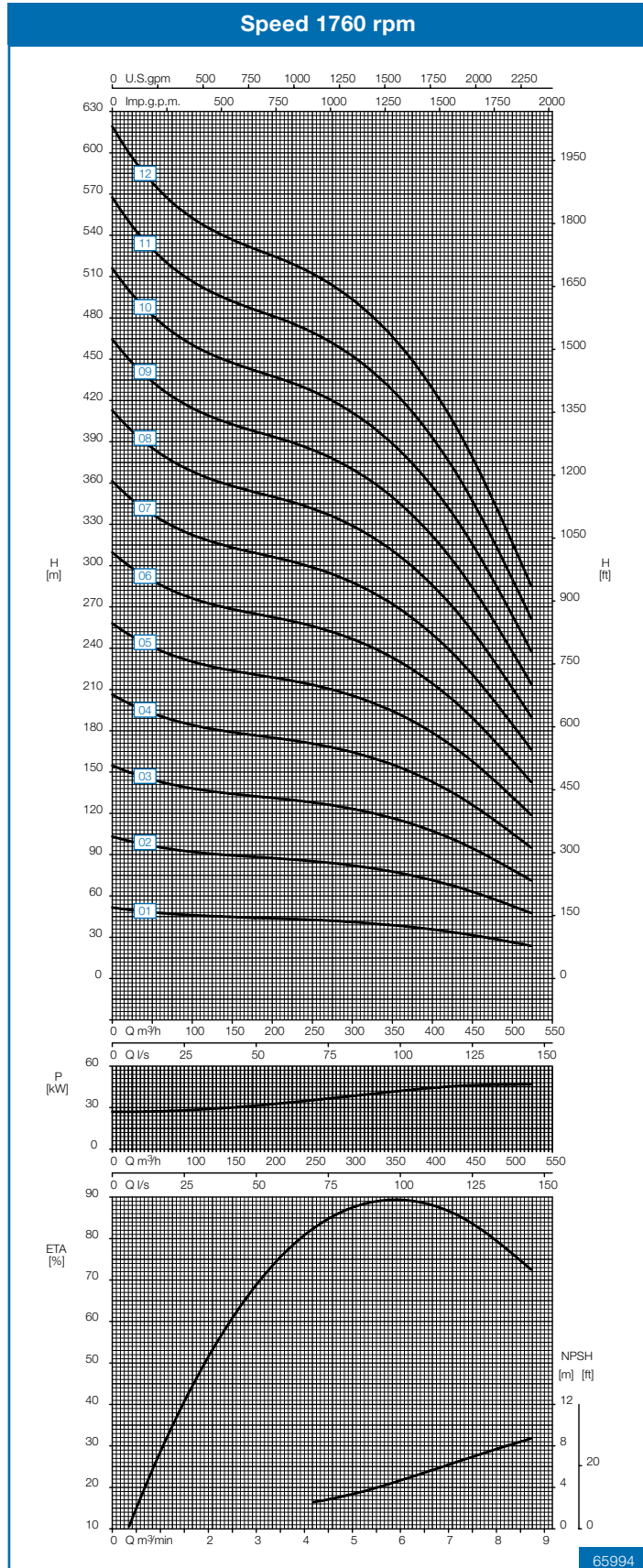

Performance curve

Type 200-360.1

Notes to performance curves

- Curves valid according to DIN EN ISO 9906/2B.
- Power data refers to clean water, density 1 kg/dm³, viscosity 1 mm²/s.
- All duty points between the individual stage characteristics can be achieved by adapting the impeller diameters.

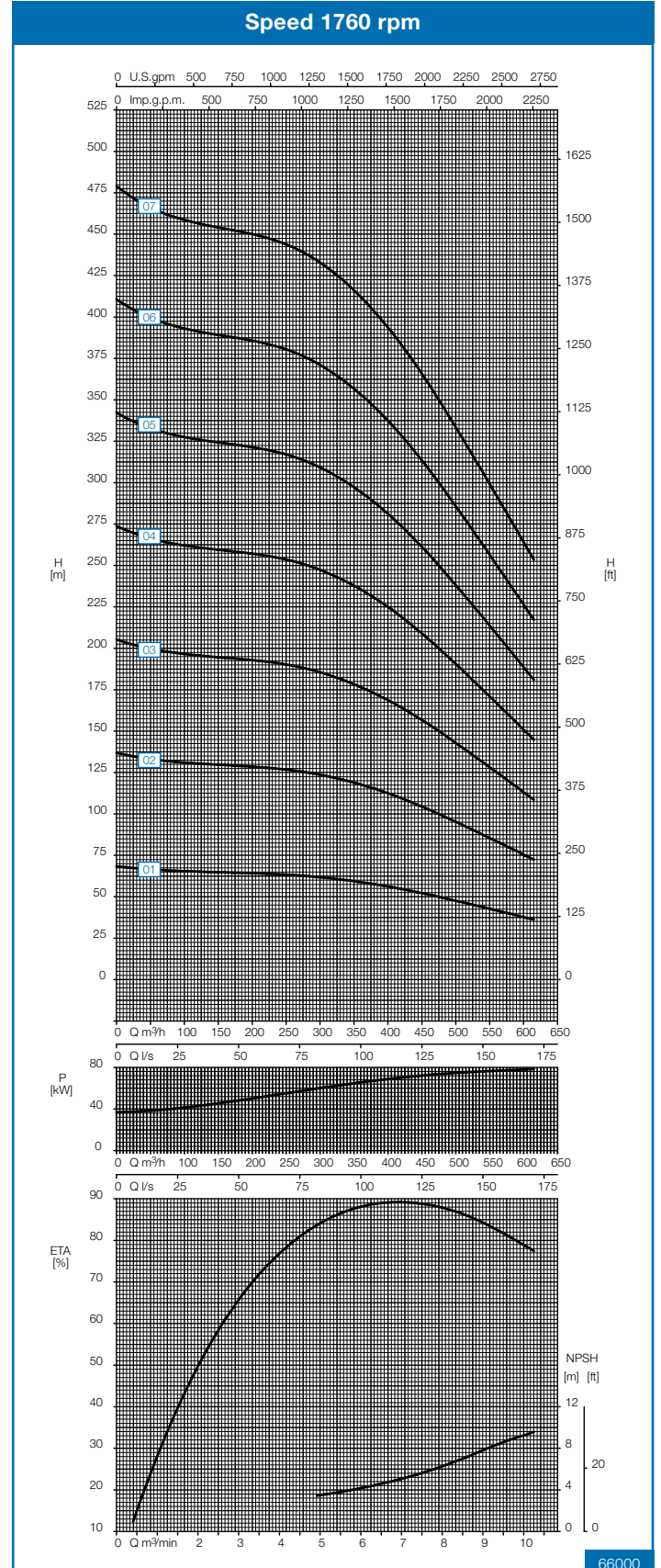
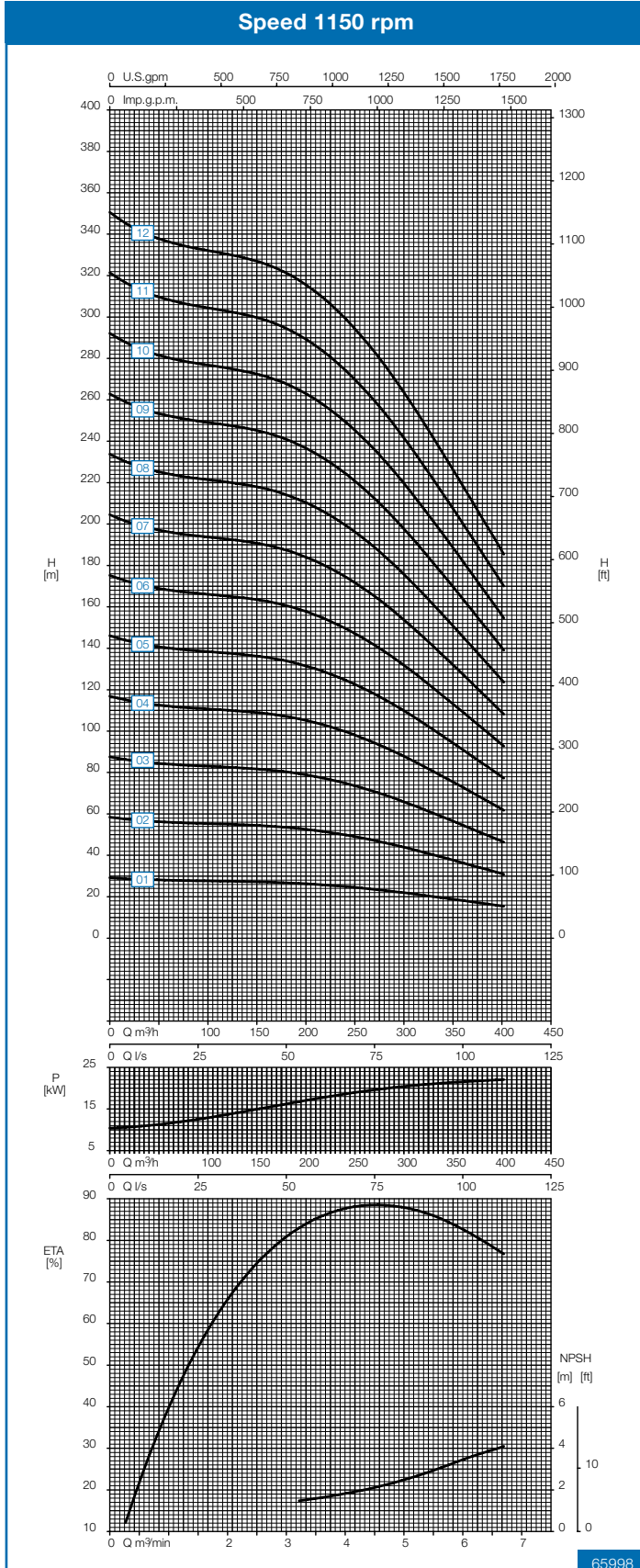

Performance curve

Type 200-360.2

Notes to performance curves

- Curves valid according to DIN EN ISO 9906/2B.
- Power data refers to clean water, density 1 kg/dm³, viscosity 1 mm²/s.
- All duty points between the individual stage characteristics can be achieved by adapting the impeller diameters.

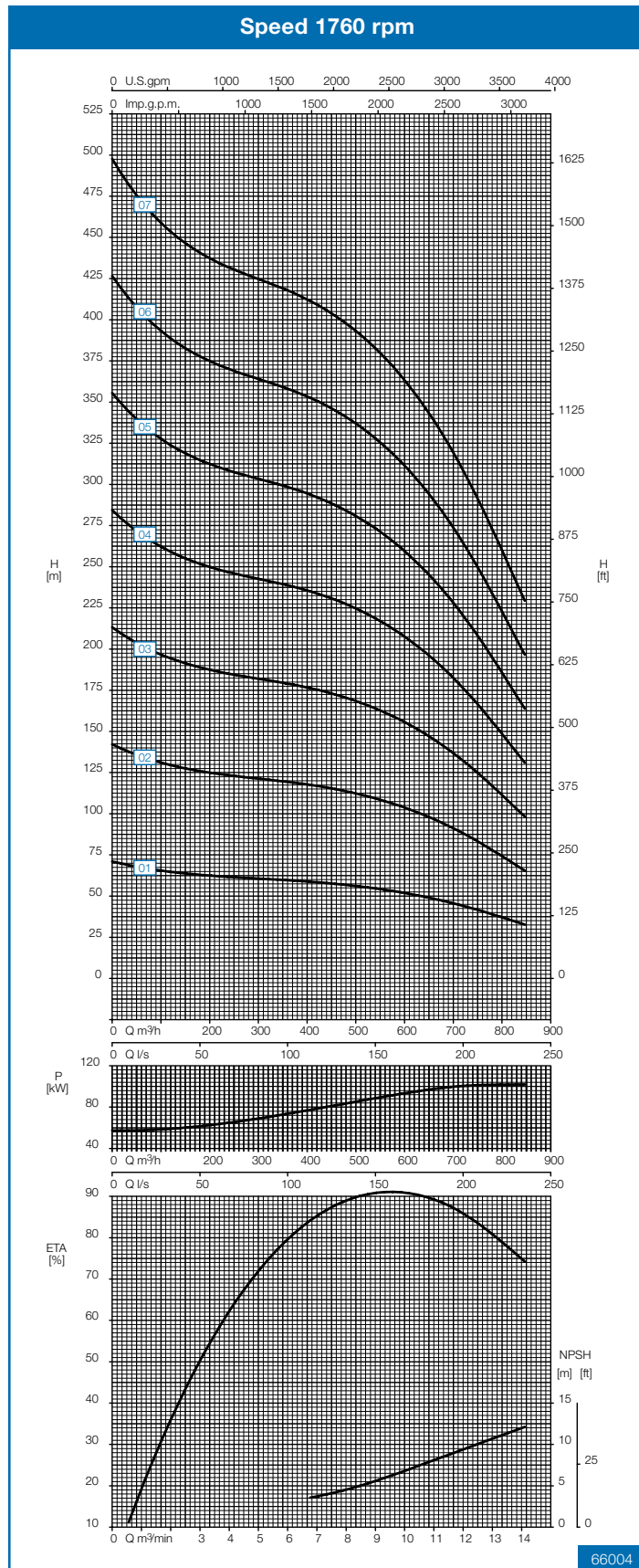
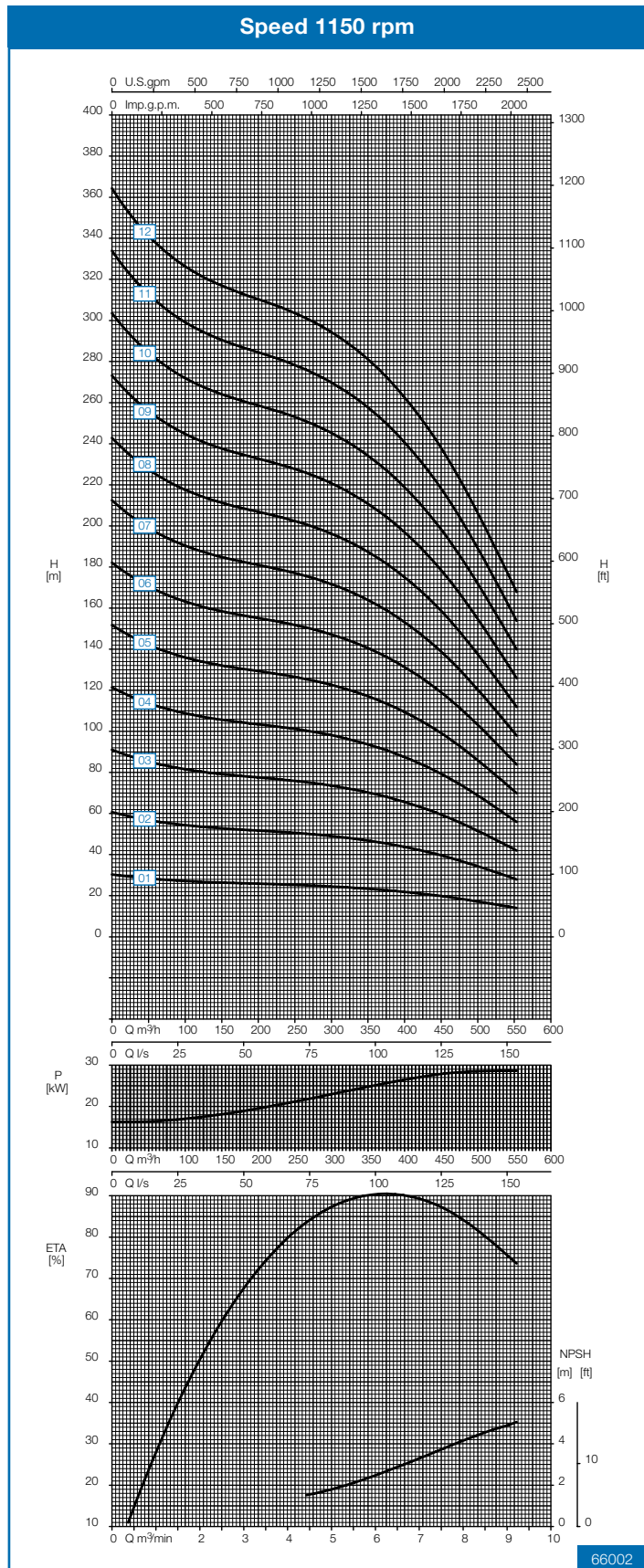

For your notes

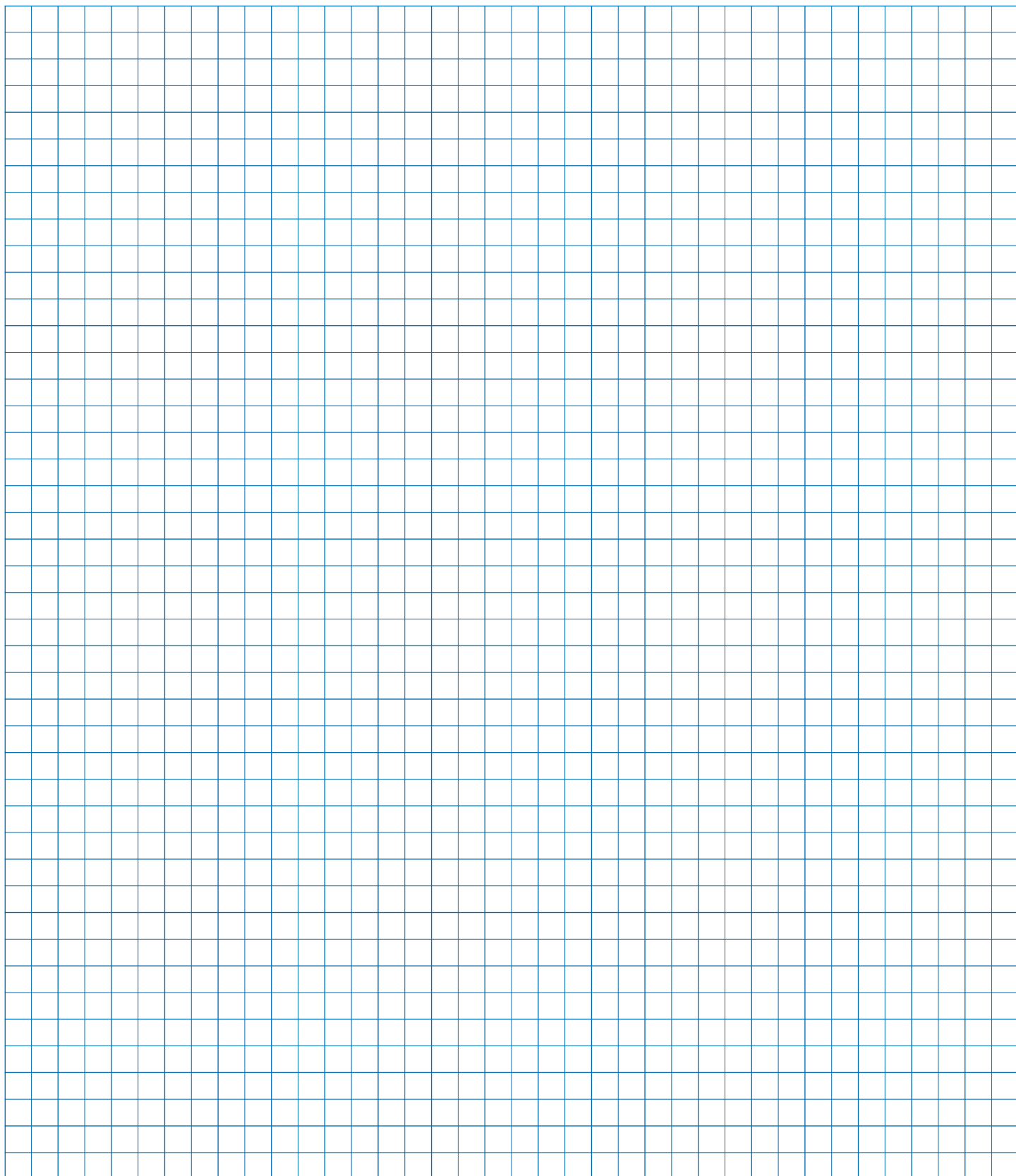

Close to our customers



ANDRITZ Ritz GmbH

Güglingstraße 50
73529 Schwäbisch Gmünd, Germany
Phone: +49 (0)7171 609 0
Fax: +49 (0)7171 609 287
ritz@andritz.com



www.andritz.com/pumps

All data, information, statements, photographs and graphic illustrations made in this leaflet are without any obligation and raise no liabilities to or form part of any sales contracts of Andritz AG or any affiliates for equipment and/or systems referred to herein. © Andritz AG 2016. All rights reserved. No part of this copyrighted work may be reproduced, modified or distributed in any form or by any means, or stored in any database or retrieval system, without the prior written permission of Andritz AG or its affiliates. Any such unauthorized use for any purpose is a violation of the relevant copyright laws. Andritz AG, Stattegger Strasse 18, 8045 Graz, Austria.